

307Pro • 310Pro CT

Climate Controller

User Manual



Big Dutchman.

Manufacturer: SKOV A/S
Address: Hedelund 4, DK-7870 Roslev, Denmark
Telephone: +45 72 17 55 55

This declaration of conformity is issued under the sole responsibility of the manufacturer.

Product: 310Pro series
Type, model: Controller

EU directives: 2011/65/EU RoHS Directive
2014/30/EU Electromagnetic Compatibility (EMC)
2014/35/EU Low Voltage Directive (LVD)

Standards: EN 63000:2018
EN 61000-6-2:2019
EN 61000-6-4:2019
EN 62368-1:2020/AC:2020

We declare as manufacturer that the products meet the requirements of the listed directives and standards.

Location: Hedelund 4, DK-7870 Roslev

Date: 2023.09.01



Tommy Bak
CTO



Product and Documentation Changes

Big Dutchman reserves the right to change this document and the product herein described without further notice. In case of doubt, please contact Big Dutchman.

The date of change appears from the front and back pages.

IMPORTANT

Notes concerning alarm systems

Breakdowns, malfunctions or faulty settings may cause substantial damage and financial losses when regulating and controlling the climate in a livestock house. It is therefore essential to install a separate, independent alarm system that monitors the house climate concurrently with the climate and production controller. According to EU-directive No. 98/58/EU, an alarm system must be installed in all mechanically ventilated houses.

We would like to draw your attention to the fact that the product liability clause of general terms and conditions of sale and delivery specifies that an alarm system must be installed.



In case of an operating error or inappropriate use, ventilation systems can result in production losses or cause loss of lives among livestock.









We recommend that ventilation systems should be mounted, operated and serviced only by trained staff and that a separate emergency opening unit and an alarm system be installed as well as maintained and tested at regular intervals, according to terms and conditions of sale and delivery.

Installation, servicing and troubleshooting of all electrical equipment must be carried out by qualified personnel in compliance with the applicable national and international standard EN 60204-1 and any other EU standards that are applicable in Europe.

The installation of a power supply isolator is required for each motor and power supply to facilitate voltage-free work on the electrical equipment. The power supply isolator is not included.

Note

- All rights belong to Big Dutchman. No part of this manual may be reproduced in any manner whatsoever without the expressed written permission of Big Dutchman in each case.
- All reasonable efforts have been made to ensure the accuracy of the information contained in this manual. Should any mistakes or imprecise information occur in spite of this, Big Dutchman would appreciate being notified thereof.
- Irrespective of the above, Big Dutchman shall not accept any liability with regard to loss or damage caused or alleged to be caused by reliance on any information contained herein.
- Copyright by Big Dutchman.

1	Guidelines	8
2	Product description	9
3	Operating instructions	12
3.1	Operation	12
3.1.1	Two-house variant	13
3.1.2	Selection of language	13
3.1.3	Information card	13
3.1.4	Search in menus	14
3.2	 The page Operation - pigs	15
3.3	 Report	16
3.4	 Auxiliary	17
3.5	 Activity log	18
3.6	 Menu button	19
3.6.1	 Between batches - In-between functions	20
3.6.2	 Strategy	22
3.6.2.1	Setting curves	22
3.6.3	 Settings	23
3.6.3.1	System	23
3.6.3.1.1	Password	23
3.6.3.2	Alarms	25
3.6.3.2.1	Stopping an alarm signal	26
3.6.3.2.2	Power failure alarm	26
3.6.3.2.3	Alarm test	26
3.6.3.3	About	26
4	Climate	27
4.1	Automatic climate control	27
4.2	Temperature	28
4.2.1	Temperature control	28
4.2.1.1	Two-zone control	29
4.2.1.2	Heat wave comfort	29
4.2.1.3	Comfort temperature	30
4.2.1.4	Day and night adjustment	31
4.3	Humidity	33
4.3.1	Humidification	35
4.3.2	Humidity control mode	35
4.3.2.1	Humidity ventilation	36
4.3.2.2	Temperature reduction	36
4.3.2.3	Humidity heat	37
4.3.3	Intelligent humidity control - at high outside temperature and outside humidity	37
4.3.4	Humidity settings	38
4.3.4.1	Adaptive humidity ventilation	38
4.3.4.2	Adaptive humidity heat	38
4.4	Ventilation	40
4.4.1	Air quality	40
4.4.1.1	Cycle timer at minimum ventilation	42
4.4.1.2	NH3	42
4.4.2	Side ventilation	43
4.4.2.1	Ventilation settings	43
4.4.2.1.1	Inlet de-ice	44
4.4.2.1.2	Heat recovery unit	45
4.4.3	Tunnel ventilation	47
4.4.3.1	Cycle timer at tunnel ventilation	48

4.4.3.2	Chill factor and chill effect	49
4.4.4	Combi-Tunnel ventilation	50
4.4.4.1	Combi-tunnel ventilation: change between side and tunnel.....	51
4.4.5	Natural ventilation	51
4.4.5.1	Pure natural ventilation	52
4.4.5.2	Natural ventilation combined with mechanical ventilation.....	54
4.4.5.3	Natural ventilation using CO2 sensor	56
4.4.5.4	Natural ventilation using weather station	56
4.4.6	Pressure.....	57
4.4.6.1	Equal pressure ventilation.....	58
4.4.7	Ventilation status.....	58
4.4.8	Parking of fans	58
4.4.9	Stir fan.....	59
4.4.9.1	Regulation via 24-hour clock.....	59
4.4.9.2	Regulation via temperature	60
4.4.9.3	Regulation via heat source	62
4.4.10	Weather station.....	64
4.5	Delivery	65
4.6	Cooling.....	66
4.6.1	Cooling potential	66
4.6.2	Side cooling	66
4.6.2.1	Start cooling	68
4.6.2.1.1	Side cooling start based on ventilation level	68
4.6.2.2	Nozzle cleaning.....	70
4.6.3	Spraying and behavior control	71
4.6.3.1	Spray sequence	71
4.6.3.2	Limitation of spraying	72
4.6.4	Behavior control	73
4.6.5	Tunnel cooling.....	74
4.6.5.1	Tunnel cooling settings	74
4.6.5.2	Start cooling	74
4.6.5.2.1	Tunnel cooling start based on a fixed air speed	75
4.6.5.2.2	Tunnel cooling start based on an adapted air speed	75
4.6.5.2.3	Tunnel cooling start based on inside temperature	76
4.6.5.3	Pad rinsing.....	76
4.7	Heating.....	78
4.7.1	House heaters.....	78
4.7.1.1	Minimum heating.....	79
4.7.2	Stand-alone heating.....	80
4.7.3	Floor heating	80
4.8	House status Active house - Empty house	83
4.8.1	Empty house safety	84
4.9	Between batches.....	85
4.9.1	Soaking	85
4.9.2	Washing.....	86
4.9.3	Disinfection	86
4.9.4	Drying.....	87
4.9.5	Empty house	88
4.9.5.1	Preheating.....	88
4.9.5.2	Temperature surveillance	89
5	Production	90
5.1	Animals	90
5.2	Pig weighing.....	90
5.3	Water	91
5.4	Light	92
5.4.1	Light program.....	92
5.4.2	Main light.....	92

5.4.3	Dawn and dusk	93
5.4.4	Inspection light	93
5.5	24-hour clock.....	94
6	Alarm settings	95
6.1	Climate	95
6.1.1	Temperature alarms.....	95
6.1.2	Humidity alarm	96
6.1.3	Inlet and outlet alarm	96
6.1.4	Sensor alarm.....	97
6.1.5	Tunnel cooling sensor alarm.....	97
6.1.6	Pressure sensor	98
6.1.7	CO2 alarm.....	98
6.1.8	NH3 alarm.....	98
6.1.9	Weather station alarm.....	98
6.1.10	Heat recovery alarm.....	98
6.1.11	Dynamic Air Alarm	99
6.1.12	Emergency control	99
6.1.12.1	Emergency opening	99
6.1.12.2	Temperature-controlled emergency opening	99
6.1.12.3	Emergency inlet	100
6.2	Production	100
6.2.1	Light alarms	100
6.2.2	Water alarms.....	100
6.3	Auxiliary.....	102
6.3.1	Auxiliary sensor alarm.....	102
6.3.2	Auxiliary alarms.....	102
6.4	Master/Client alarms.....	102
6.5	Equipment status.....	102
7	Maintenance instructions	104
7.1	Cleaning.....	104

1 Guidelines

This user manual deals with the daily operation of the controller. The manual provides fundamental knowledge about the functions of the controller that is required to ensure optimum use of it.

The user manual describes the general operation of the controller and all climate functions. A description of production functions can be found in the appurtenant user manual for production.

If a function is not used, e.g. **24-hour clock**, it is not shown in the user menus of the controller. The manual may therefore contain sections that are not relevant to the specific setup of your controller. See also *Technical Manual* or contact service or your dealer, if required.

10" and 7" controller display

The displays shown in this manual are from a 10" controller display where the menu overview is shown to the left in the display. If you use a controller with a 7" display, the menus are shown in the middle of the display.

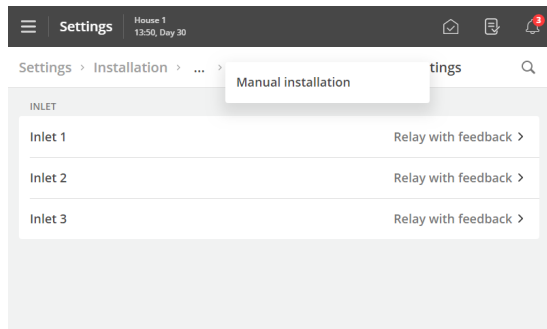

Using a 7" display you can press the menu headlines at the top of the display to go back step-by-step in the menus.

If more steps are available that what can be shown, you can press the 3 dots and select a menu from the appearing list.

2 Product description

310Pro is a one- or two-house climate controller for pig houses, which can regulate and monitor the climate in the house.

A page setup adapted to the needs of pig producers

The controller has 6 main pages, which are adapted to pig production and a menu page. The pages contain selected functions and views relevant to the daily work.

The page Operation

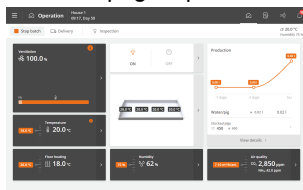

The page Activity log

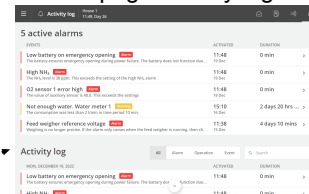

The page Report

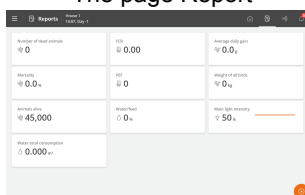

The page Strategy

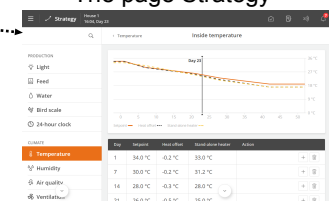

The page Menu

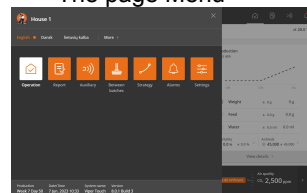

The page Between batches

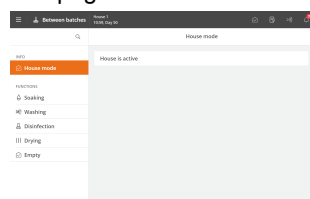

The page Auxiliary

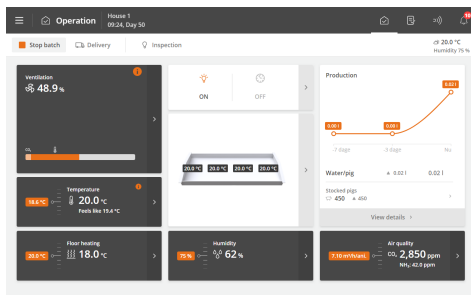
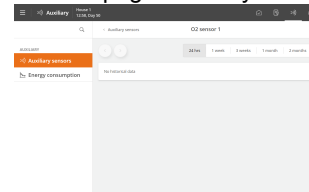

 The page **Operation**

The page is the main page view where the functions used for daily operation are gathered.

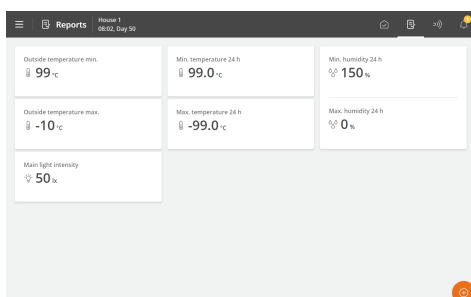

 The page **Report**

The page can be set up according to the user's wishes to contain cards with key values showing current data.

It can thus be used to collect values that must be read daily and collect data to be reported.

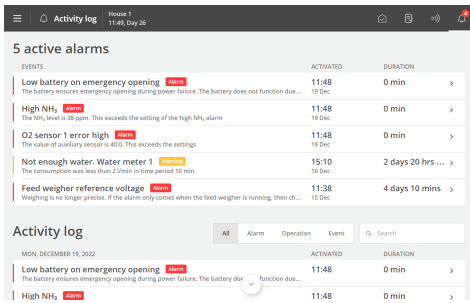

The page **Activity log**

The page displays a log of all recorded alarms, operations of the controller and events.

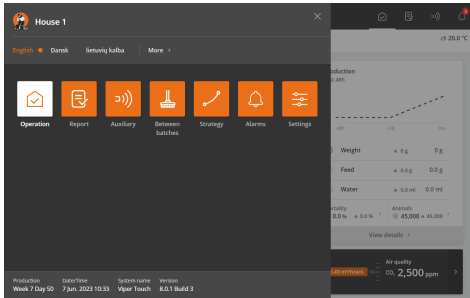

Menu button

The button gives access to language selection and to a collection of shortcuts to the various pages.

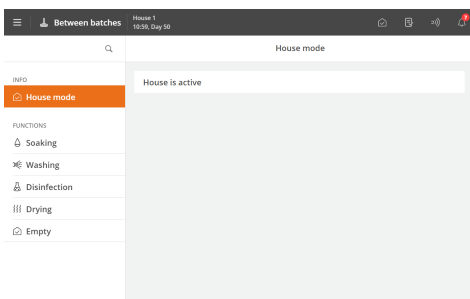

| The page **Between batches**

The page gives access to functions designed partly to facilitate the activities you must carry out in the house to clean it and prepare it for the next batch and partly to ensure the air change and temperature in the house while it is empty.

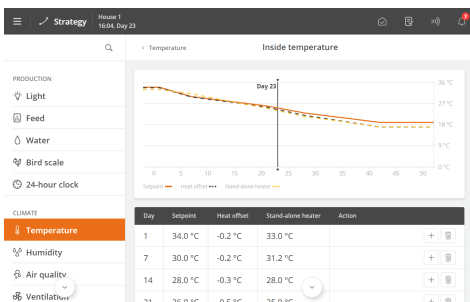

| The page **Strategy**

The page gives access to determination of the desired production strategy, which must be repeated from batch to batch.

These are, for example, program settings, references, and batch curves.

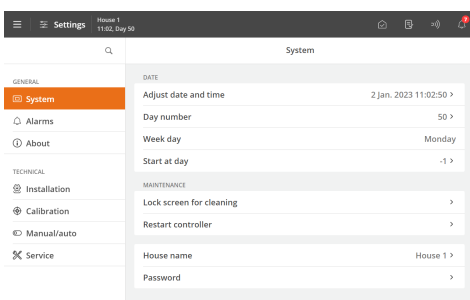

| The page **Settings**

The page provides access to general settings and alarm limits.

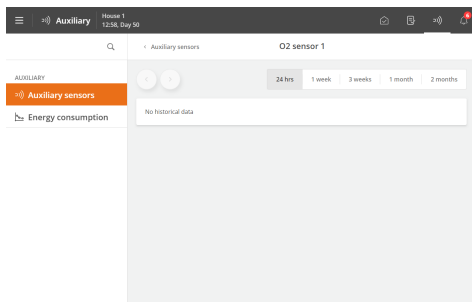

The page **Auxiliary**

The page gives access to graphical displays of historical data from various types of additional equipment (auxiliary sensors and energy meters).

The page is only displayed if additional equipment is installed.

3 Operating instructions

3.1 Operation

Each page is composed by different types of cards that provide information about the operation and quick access to operation.

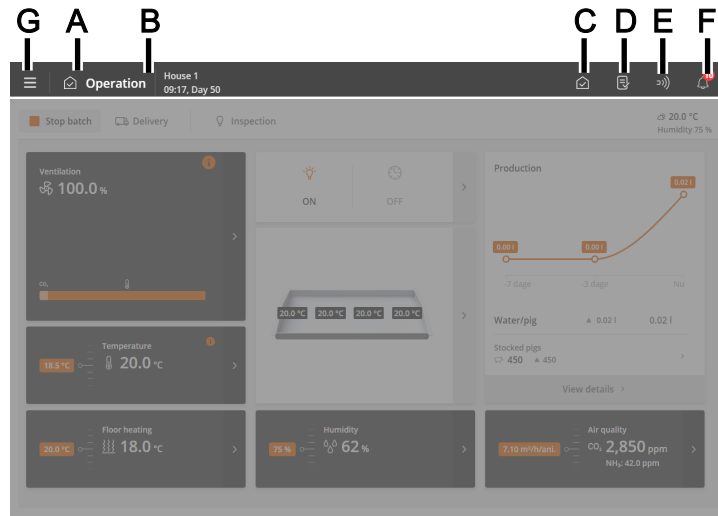

From the top bar of the page, there are shortcut buttons that allow you to switch between the main pages **Operation (C)**, **Report (D)**, **Auxiliary (E)** and **Activity log (F)**.

- A** The icon and name of the page.
- B** The house name, time, and possibly week and day number.
- C** The **Operation** page provides an overview and the ability to operate the functions most needed for your daily work.
- D** The **Reports** page shows the key values the user wants on the page.
- E** The **Auxiliary** page displays the consumption figures and auxiliary equipment status (if installed).
- F** The **Activity log** page displays active alarms and a complete log of operations, events, and alarms.
- G** The menu button gives access to language selection (see section Selection of language [▶ 13]) and other pages: **Between batches**, **Strategy**, and **Settings**.

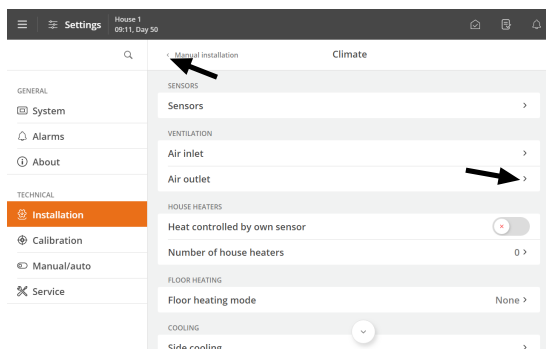

Navigation menus provide access to sub-menus.

➤ The right arrow displays a sub-menu.

⏪ The left arrow in the upper left corner allows you to take one step back in the menu.

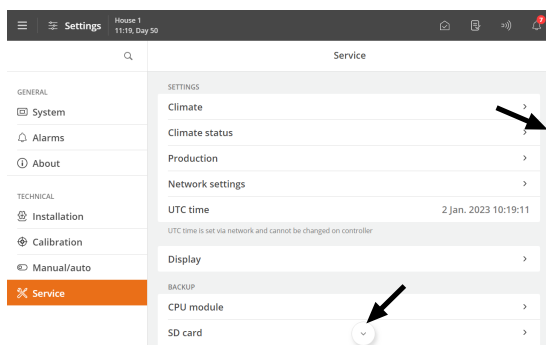

Scroll

If the page is higher or wider than the display, you can scroll.

This is shown in the display as arrows or a scroll bar.

Scroll by pressing the arrows or letting your finger slide across the display.

3.1.1 Two-house variant

The two-house controller have house keys for each house and a shared page view for **Operation**.

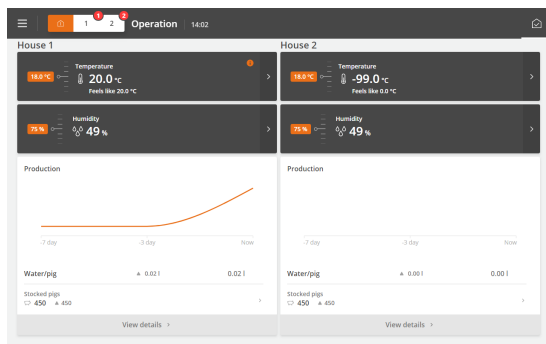

Press the house key to display a shared front view for both houses.



Press to access the overview. When you press the house key, only the shared settings for the controller are shown, if the **Settings**  menu is opened.

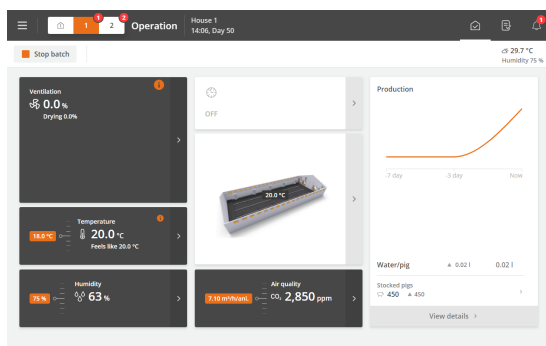

Press house key 1 or 2 to display pages for the individual house or to access the house menus.

3.1.2 Selection of language

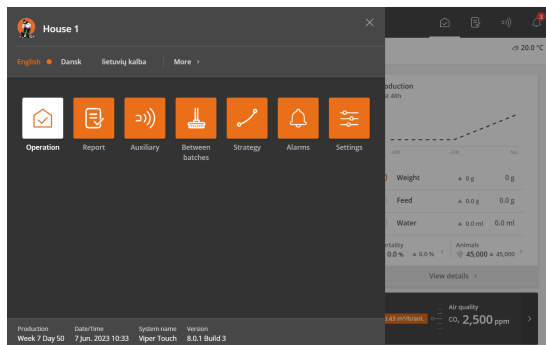

Press the  Menu button.

A dot indicates the selected language.

Press **More** if the requested language is not displayed.

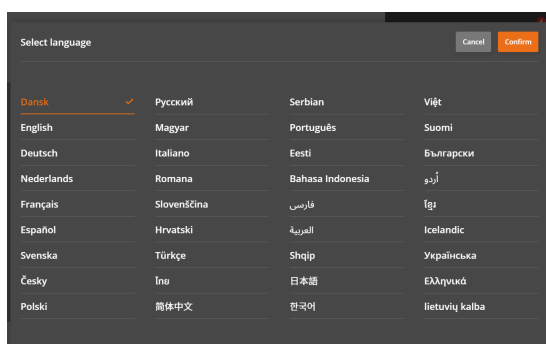

Select the language from the list. Press **Confirm**.

Note that function names (such as 24-hour clocks, water meters, and programs the user can name) are not translated into the selected language.

The factory setting for the names is English.

3.1.3 Information card

The information card is meant to give the daily user a better understanding of how the controller is working right now.

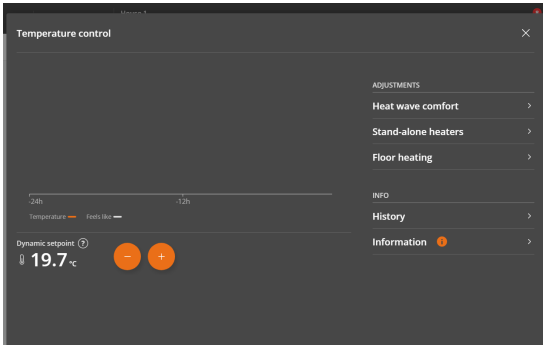

The information is available on pages with the icon .

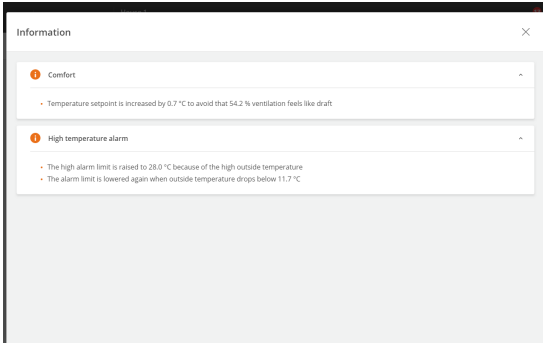

Press to view more details.

The following is described for selected control areas:

- The current status.
- The reason for the current adjustment.
- What the next step in adjustment will be.

3.1.4 Search in menus

It is easy to search for the individual functions of the controller. There are search fields on the pages: **Auxiliary, Between batches, Strategy, and Settings.**

A search across the pages is performed.

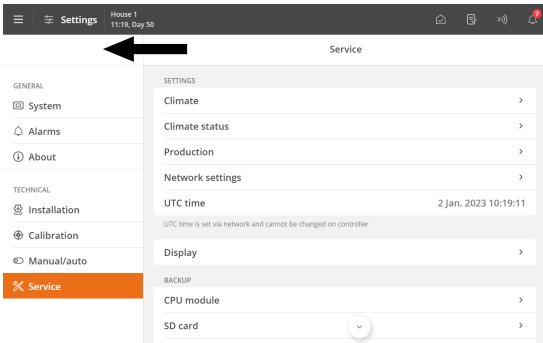

Use the search field to the left to search in menus.

Enter at least 3 characters to search.

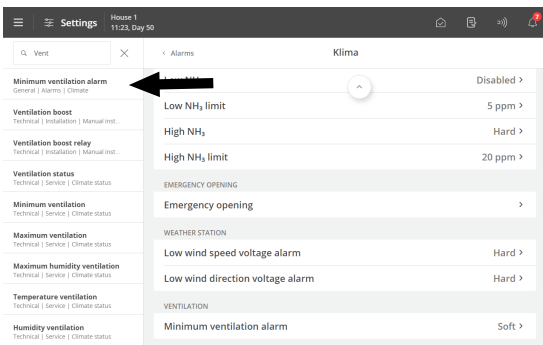

The result is shown below the search field. The path for the individual menus is also shown, for example, under Settings: **General | Alarms | Climate.**

Press a search result to go directly to that menu.

Press the X in the search field to remove the search results again.

3.2 The page Operation - pigs

The page has been adapted for pig production. It contains selected views and settings relevant to the daily work of a pig house.

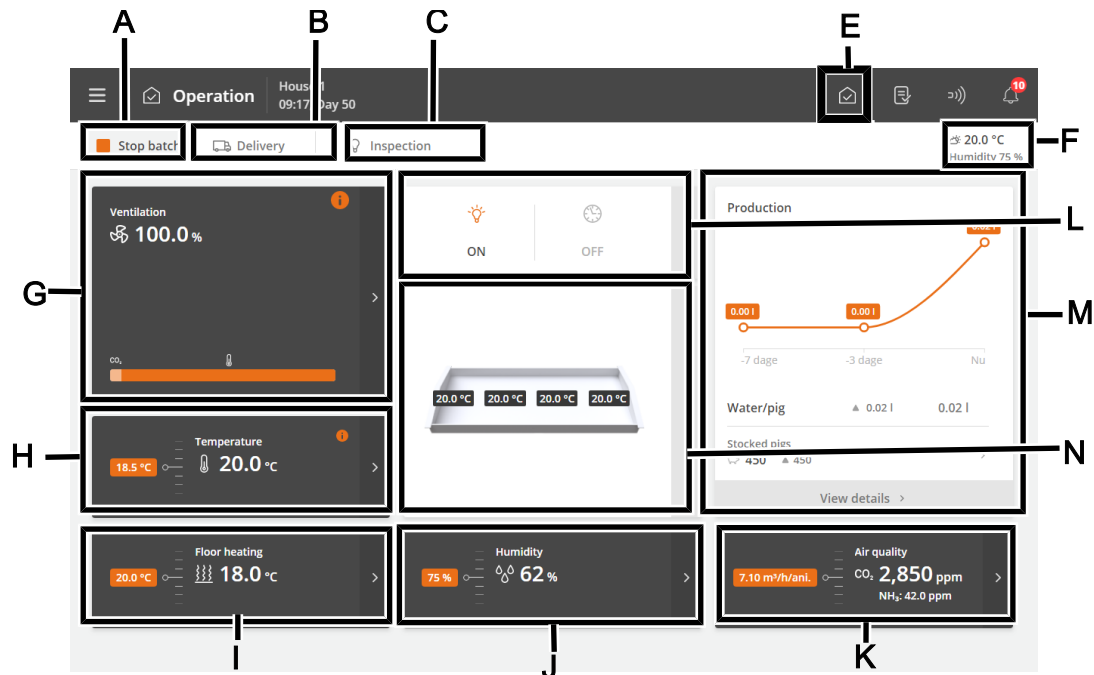

- A** The function button **Stop batch/Start batch**. See the section House status Active house - Empty house [► 83].
- B** The function button **Delivery**. The function is designed to alter the air change in the house in connection with all or some animals leaving the house.
- C** The function button **Inspection** for manually activating the inspection light.
- E** **Shortcut to the main page Operation.**
- F** View of outside temperature and outside humidity.
- G** Status display for the climate control and access to the ventilation equipment menus.
The card also provides a shortcut for manual control of the climate equipment. It is intended for situations where equipment must be stopped.
- H** Temperature settings. See section Temperature.
- I** Floor heating settings. See the section Floor heating [► 80].
- J** Humidity settings. See the section Humidity [► 33]
- K** The ventilation functions CO₂ and NH₃. See the section Air quality [► 40].
- L** Status view for climate and production functions controlled by time programs. The views also provide an overview of all applications and their associated settings.
- M** Indication of the development of the key figures for animal weight, feed and water consumption during the last 2 days. In addition, the view of calculated mortality and the current number of animals and shortcuts for recording the number of dead and moved animals.
The view also provides a shortcut to details with information and settings options.
- N** View of the current inside temperature of the individual climate sensors.

3.3 Report

The user can set up the page to include the key values that give the desired overview of climate and production values.

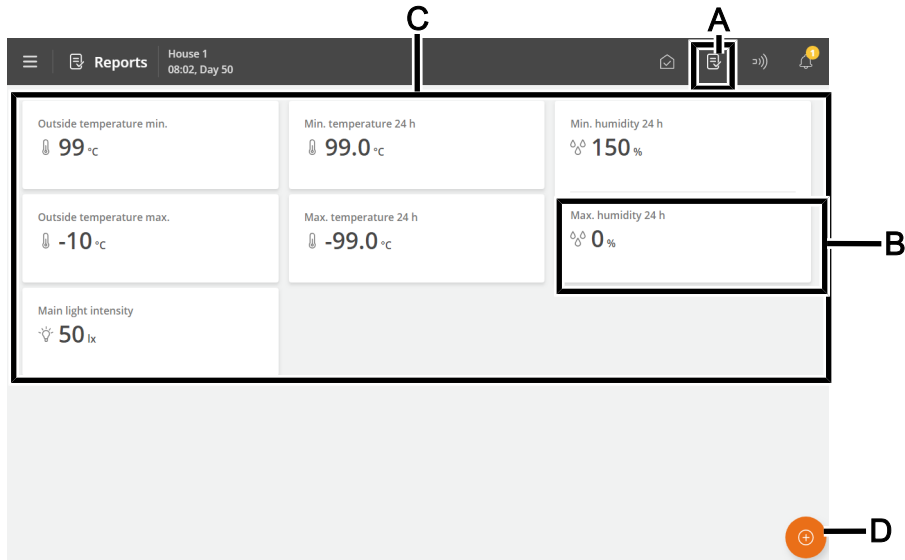

- A** Shortcut to the **Reports** page.
- B** Card with the key value. Each card can be set up to include up to 3 key values. Some key values can also comprise a small graphical history view.
- C** The page displays a series of cards with selected key values for, for example, history and current values.
- D** Edit button. Gives access to choose between the desired key values.

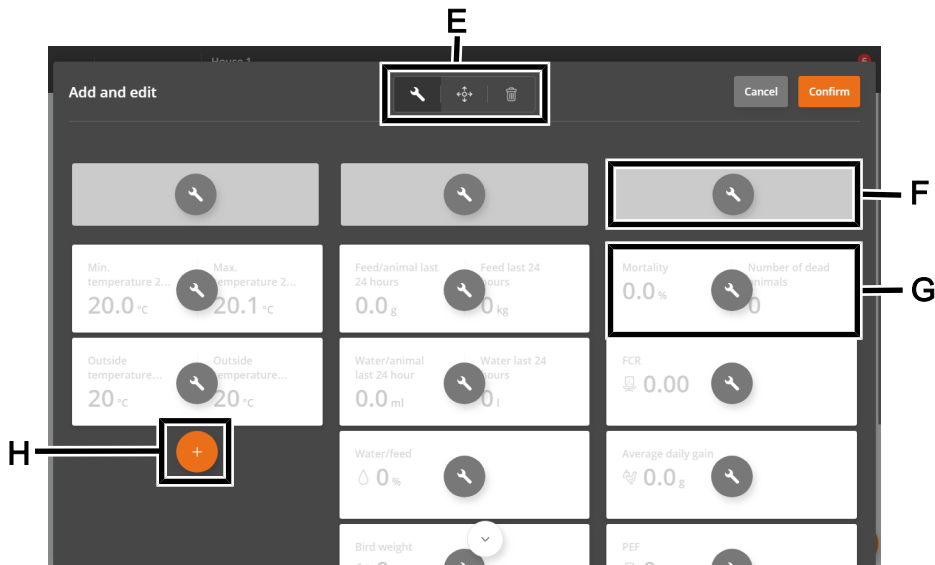

- E** Tools for editing headlines or content on cards and moving or deleting cards. First, press a tool and then make the desired change.
- F** Column header. Press to name.
- G** Card with the key value. Press to change the key value and set up its view.
- H** Tool for adding a new card in the column. Press to add a card and select the desired key value.

Cards with several key values

You can merge several cards to view up to 3 key values in one card.

If the values can be displayed as graphs, the graphs can also be shown in the card.

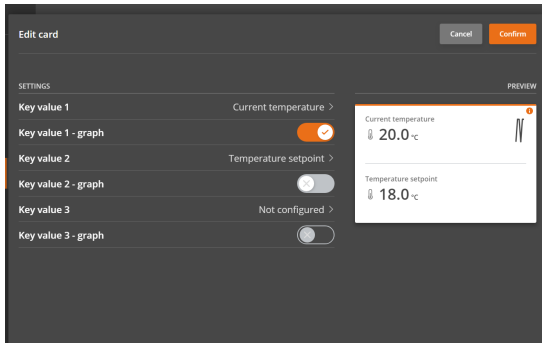

Press the editing tool .

Press on the key value to be changed.

Select Key value 2 and select the key value to be displayed.

Select Key value 3, if required and select the key value to be displayed.

To the right a preview of the card is shown.

3.4 Auxiliary

The page provides access to recordings from different types of equipment (auxiliary sensors and energy meters), which can be used for monitoring, as an example.

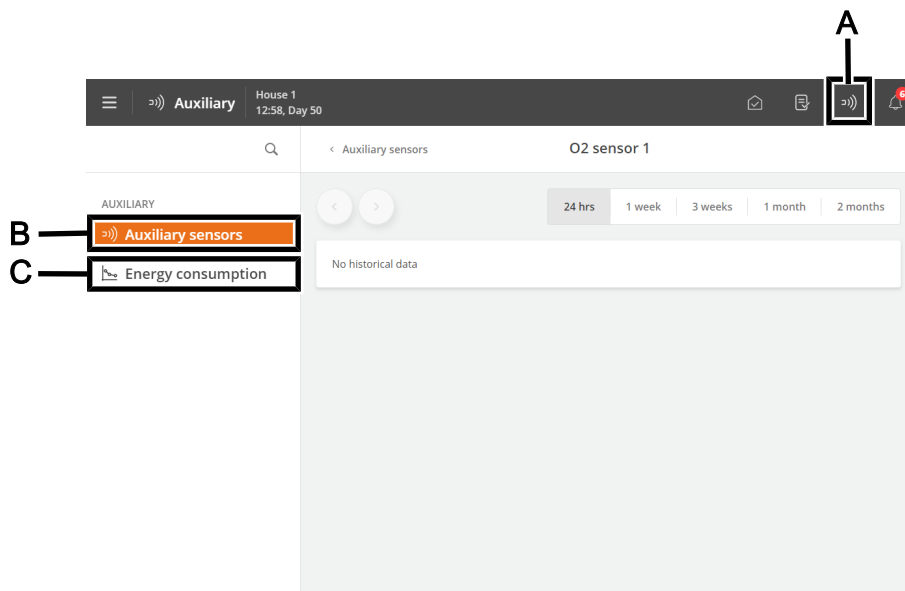

A Shortcut to the page **Auxiliary**.

B The **Auxiliary sensors** menu provides an overview of the controller recordings supplied by the auxiliary sensors in a graphical view.

The auxiliary sensors do not influence the regulation.

The controller records the content of CO₂, NH₃, O₂ in the air as well as humidity, pressure, and temperature. You can also connect air velocity and wind direction sensors that can measure the wind direction and wind velocity outside the house.

The values measured by each sensor are viewed in intervals of 24 hours to 2 months.

C The menu **Energy consumption** shows the current consumption in W and total consumption in kWh. The menu content depends on the type and the setup of the controller.

3.5 Activity log

The page displays a log of all recorded alarms, operations, and events.

Alarm status colors:

- Red – hard active alarm
- Yellow – soft active alarm (warning)
- Gray – deactivated alarm

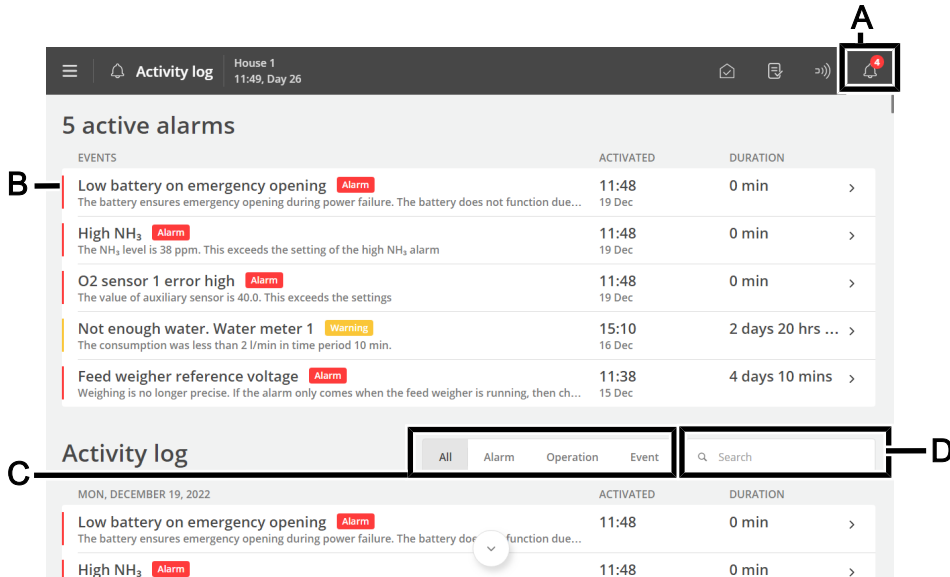

- A** Shortcut to the page **Activity log**.
The icon for the Activity log indicates the number of active alarms as long as an alarm situation has not ceased.
- B** Each line shows an activity.
Press the activity line to see details, such as when an alarm was activated and acknowledged. Also, when a value/setting was changed.
Press **Close** to close the details screen again.
- C** Filtering options for the various types of activities:
All: shows all types
Alarm: shows alarms
Operation: shows the operation of the controller
Event: shows, for example, reset of the controller
- D** Search the field for the activity log.
Enter at least 3 characters to search. It is also possible to combine filtering and search.

Several alarms often follow each other because one defective function also affects other functions. For instance, a flap alarm can be followed by a temperature alarm as the controller cannot adjust the temperature correctly with a defective flap. Thus, the previous alarms allow you to follow an alarming course back in time to detect the error that caused the alarm.

See the description of alarms in the section Alarms [▶ 25].

3.6 Menu button

The menu button gives access to language selection and general settings pages.



- A** Menu button
- B** Displaying house name, day number, time, week number, if required, variant name, and software version.
- C** Select language. Access other languages under **More**.
- Note that function names (such as 24-hour clocks, water meters), and programs the user can name are not translated into the selected language. The factory setting for the names is English.
- D** Shortcut to the page **In-between batches**.
- The page is designed partly to facilitate the activities you must carry out in the house to clean it and partly to ensure the air change and temperature in the house while it is empty.
- E** Shortcut to the page **Strategy**.
- The page provides access to the batch curves, which form the basis for controlling climate and production functions. See also the section Setting curves [▶ 22].
- F** Shortcut to the page **Settings**.
- The page provides access to the user settings for **House info**, **Alarm settings**, and **Password**. See the sections System [▶ 23], Alarms [▶ 25], and Password [▶ 23].
- In addition, you have access to the technical menus used for setup and service. See the Technical Manual.

3.6.1 **Between batches - In-between functions**

The page gives access to functions designed partly to facilitate the activities you must carry out in the house to clean it and partly to ensure the air change and temperature in the house while it is empty.

- Soaking
- Washing
- Disinfection
- Drying
- Empty

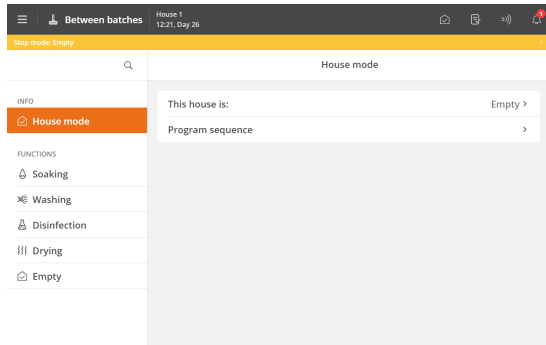

Status

The controller can only activate the functions when the house status is **Empty**.

Empty house status is indicated at the top of the page by a colored bar.

When the time of a function is up, the controller will again regulate according to the settings for **Empty house**.

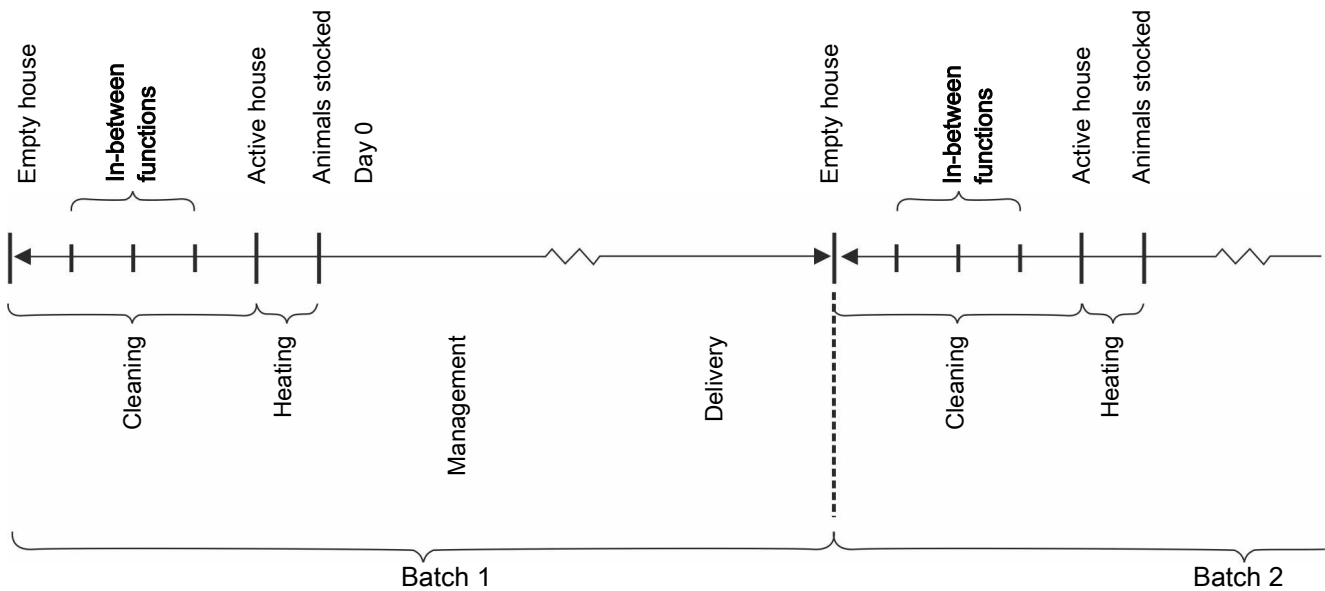

Figure 1: Setup example of the Between batches function for batch production

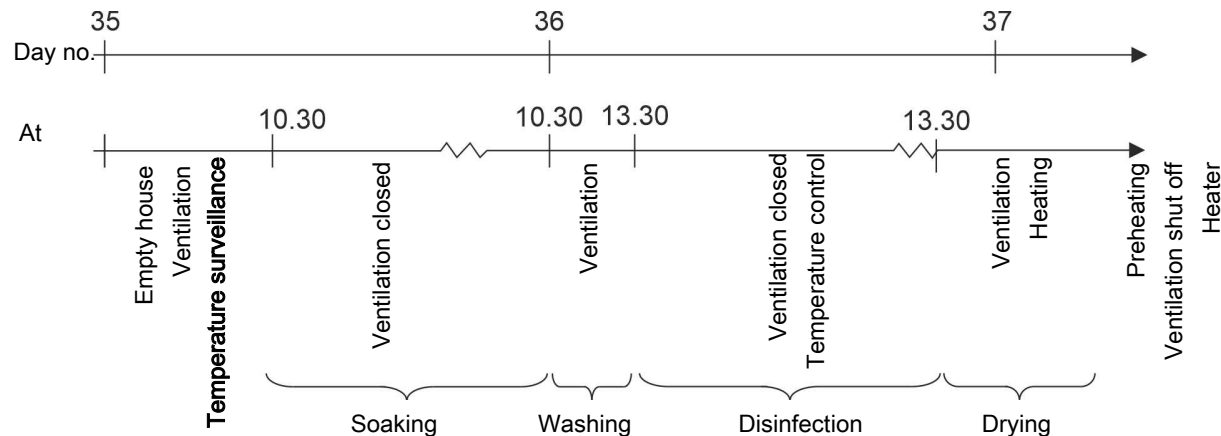
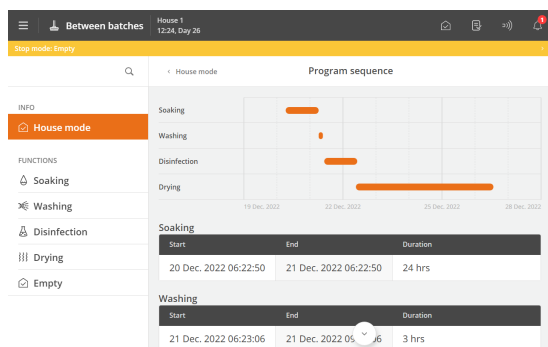

Figure 2: Sequence of functions



Program sequence

You can set up each function to start at a specified time. It is thus possible to set an entire program sequence for the functions.

 Menu button |
  Between batches |
  Info |
  House mode |
 Program sequence

This house is: Function selection menu (only displayed when the house status is **Empty**).

Function remaining time When a function is activated, the set time counts down (only displayed when the house status is **Empty**).

Program sequence Menu for setting the start time and function duration (only displayed when the house status is **Empty**).

Also see the section Between batches [▶ 85] for a description of the various functions.

3.6.2 Strategy

The page provides access to the more constituent function settings that you typically do not need to change during a batch. The strategies are thus determined in light of the overall requirements for the production.

It is where batch curves for temperature and light are set up, sub-functions such as nozzle cleaning for cooling are selected, and limit value settings are made.

See the relevant section below for a description of the various functions.

Together with other information, the curve settings form the basis of the controller's calculation of climate regulation. The controller can adjust automatically according to the animals' age.

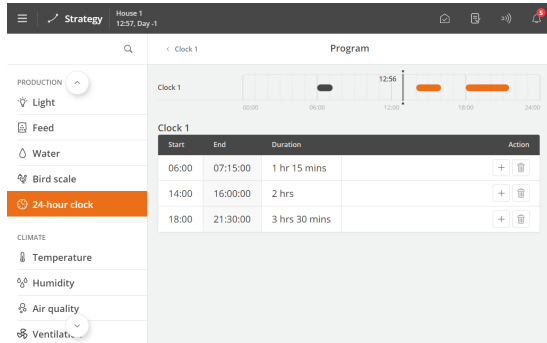

Depending on the type and setup of the controller, the following batch curves may be available:

- Inside temperature
- Heat offset temperature
- Stand-alone heater temperature
- Humidity
- Minimum ventilation
- Maximum ventilation
- ...

When the controller is connected to a network with the management program BigFarmNet Manager, curves can also be changed via BigFarmNet.

3.6.2.1 Setting curves

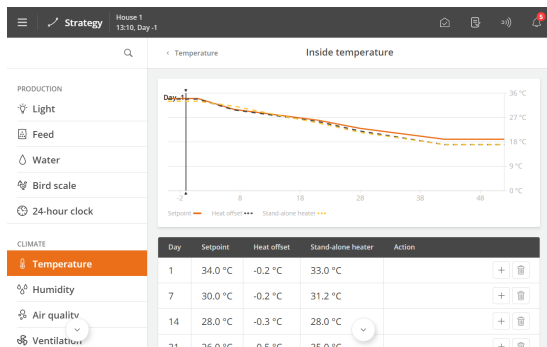

Menu button | Strategy

Set up for each curve:

- A day number for each of the required curve points.
- The desired value of the function for each curve point.

Press + to add the required number of curve points.

Typically, the last day number of the batch curve is set to match the expected production time.

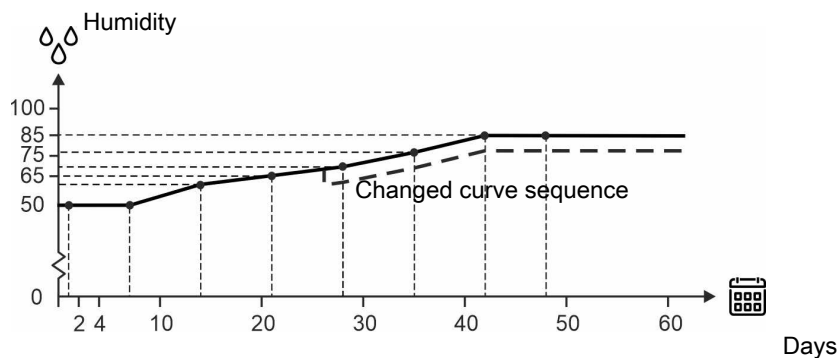

Figure 3: Curve for air humidity

It is generally the case for the curve functions that the controller automatically displaces the rest of a curve sequence in parallel when you change the associated setting during a batch.

3.6.3 Settings

The page provides access to general settings and alarm limits.

3.6.3.1 System

 Menu button |  Settings | General |  System

Adjust date and time	<p>Setting current date and time.</p> <p>Correct clock setting is important for several control functions and alarm recording. Thus, all controller programs use date, time, and day number.</p> <p>The clock will not stop in the event of a power failure.</p> <p>Summer and wintertime</p> <p>There is no automatic adaptation in summer and winter, as some animal types are very sensitive to changes in their circadian rhythm. If you want the controller to follow the local time for summer and winter, you must manually change the time setting by +/- 1 hour.</p>
Day number	<p>Select whether the day number should show the time since the batch start or the actual age of the animals. When the actual age of the animals is required, the day number must be adjusted until it matches the life expectancy.</p> <p>Setting day number. At midnight, the day number counts up 1 every 24 hours after the house has been set to active house.</p> <p>Please note that if the day number is changed during a batch, it will shift/destroy the historical data of the batch (feed consumption, etc.).</p> <p>The function Day number can also be used to preheat the house by setting a number of minus days.</p>
Week day	Viewing week day.
Start on day	<p>Setting the day on which the batch shall start.</p> <p>Day number can be set as low as -3 so the controller can control the preheating of the house before the animals are stocked.</p>
House name	<p>Setting house name.</p> <p>Each livestock house must have a unique name when the controller is integrated with a LAN network. The house name is transferred through the network, and the livestock house should be identifiable based on the name.</p> <p>Set up a plan for naming all controllers connected to the network.</p>
Password	<p>Decide whether the controller must be protected against unauthorized operation using passwords.</p> <p>See section Password [▶ 23].</p>

3.6.3.1.1 Password

This section is only relevant to houses where the Password function is activated.

The controller can be protected against unauthorized operation using passwords.

In order to have access to changing a setting, a password must be entered that corresponds to the user level which the relevant function is found at (**Daily**, **Advanced** and **Service**).

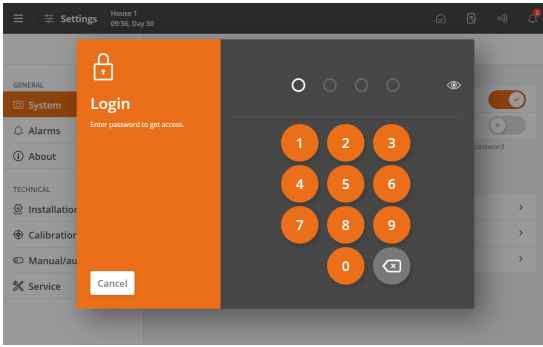

Menu button | Settings | General | System | Password to access the activation of the function.

Enter a service password.

After entering the password, the controller can be operated at the corresponding user level. After 10 minutes without operation, the user is automatically logged out.

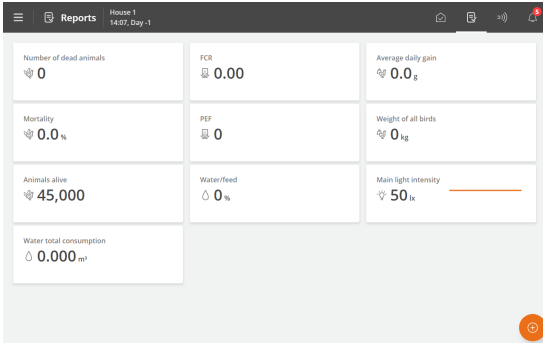

Select a page after an operation. After 1 minute, the controller will request the password again.



Activate the function **Use password for technical menu only** to make the controller require the **Service** password only when the user wants to change settings in the menus **Installation**, **Calibration**, and **Service**.

Change password for each of the 3 user levels.

To gain access to changing a password a valid password must first be entered.

Menu button | Settings | General | System | Password.

User level	Gives access to	Factory-set code
Daily view (without login)	Entry of number of animals Fine-tuning of temperature, humidity, and air quality Manual climate control	
Daily	Daily: Changing set values	1111
Advanced	Daily + advanced: Changing curves and alarm settings Manual production control	2222
Service	Daily + advanced + service: Changing settings under Technical menu	3333



Access limitation to operate the controller

We recommend that you change the default passwords and subsequently change the password regularly.

3.6.3.2 Alarms



Alarms only work when the status is Active house.

The only exceptions are alarm tests and alarms for CAN communication and temperature surveillance at **Empty**.

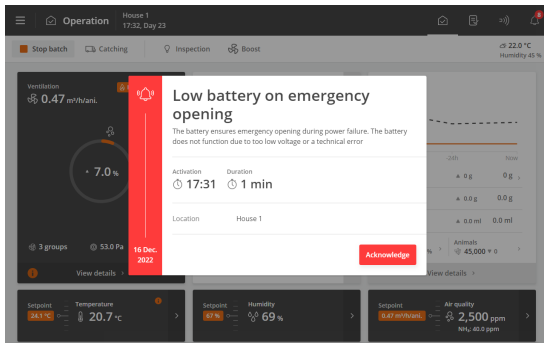

The controller will record the alarm type and time when an alarm occurs.

The information on the type of alarm will appear in a separate alarm window, together with a short description of the alarm situation.

Red: hard alarm

Yellow: soft alarm

Gray: deactivated alarm (alarm state ceased)

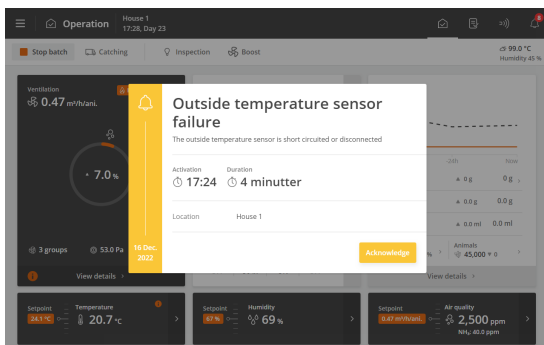

You can choose whether the alarm should be hard or soft for selected climate and production alarms.

Hard alarm: Red alarm pop-ups on the controller and generation through the connected alarm units, e.g., a horn. Only hard alarms trigger the alarm relay.

Soft alarm: Yellow pop-up alert on the house controller. Soft alarms generate a pop-up in the display.

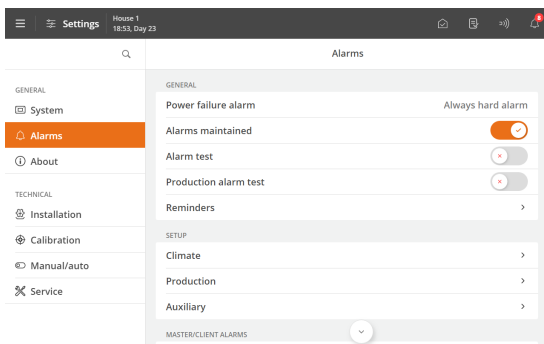

The controller will also trigger an alarm signal, which you can choose to maintain.

The alarm signal will thus continue to sound until you acknowledge the alarm. It also applies even if the situation that triggered the alarm has ceased.

 Menu button |  Settings |  Alarms

Alarms maintained: Selecting whether the alarm signal should continue after the alarm condition has ceased.

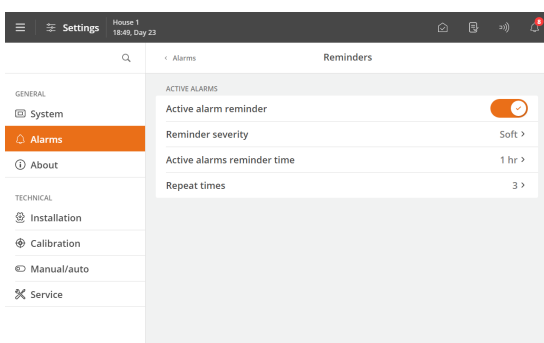

Reminder

The controller can remind you of an ongoing alarm once you have acknowledged a hard alarm. It should ensure that the cause of the alarm is handled.

Reminder settings:

Active alarms reminder time: Setting how long after the alarm, the reminder is to appear.

Repeat times: Setting how many times the reminder is to appear.

See section Climate [▶ 95] for setting the alarm and alarm limits.

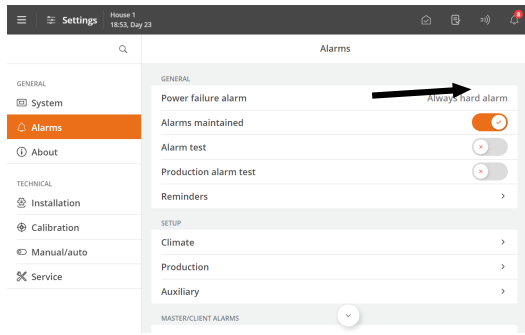

Switch change

When the controller is connected to an override switch module, an alarm is available for changing the module's switch position.

Changes in the switch position are logged in the Aktivitet-sloggen.

3.6.3.2.1 Stopping an alarm signal

The alarm window disappears, and the alarm signal stops when you acknowledge the alarm by pressing **Acknowledge**.

3.6.3.2.2 Power failure alarm

The controller will always generate an alarm and activate emergency opening in the event of power failure.

3.6.3.2.3 Alarm test

Regular alarm tests help to ensure that the alarms actually work when needed. Therefore you should test the alarms every week.

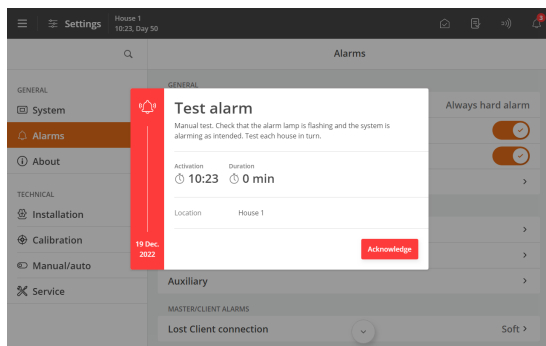

Activate **Alarm test** to start testing.

Check that the alarm lamp is flashing.

Check that the alarm system alarms as intended.

Press **Acknowledge** to finish testing.

3.6.3.3 About

The menu item contains information about types and versions of software and hardware.

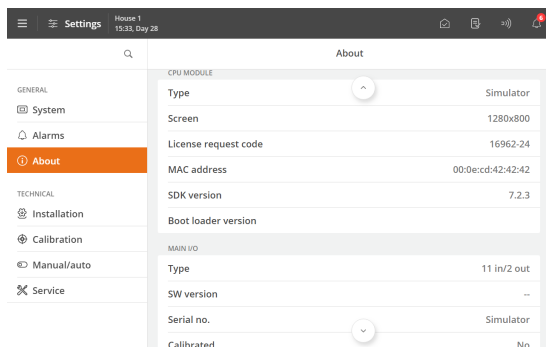

Furthermore, under **CPU module** you can see the license order code, which must be used when ordering additional software, e.g. production add-ons.

4 Climate

4.1 Automatic climate control

The controller automatically regulates and monitors a large number of factors that are important for the climate in the house - e.g. air change and temperature. It can regulate very precisely and maintain the required temperature and humidity level in the house.

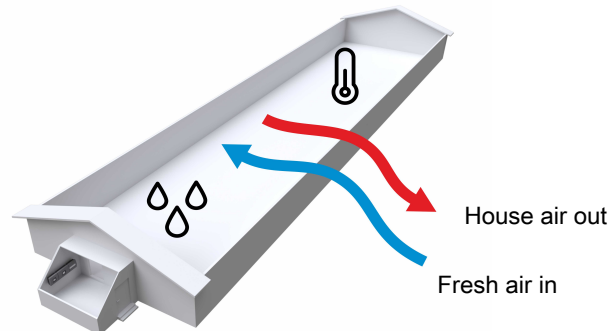

With correct setup of the controller, the daily user of the house should only exceptionally need to make manual changes to the settings.

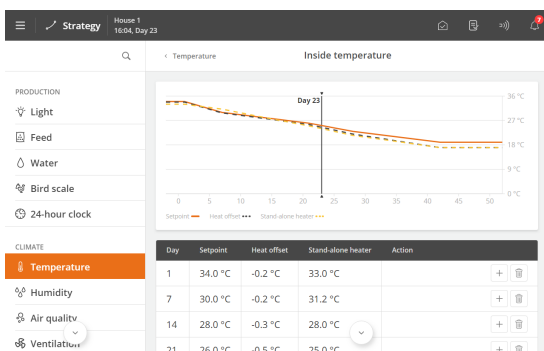

The controller will continuously adapt the climate to the animals' age and needs on the basis of the strategy laid out.

In addition, it can via its adaptive functions adapt the regulation to the very current conditions such as e.g. changing outside temperature.

Manual mode

Normally the controller must be set to automatic control. During start up, or in a service situation, it may however be convenient to control the individual functions manually.



After the manual operation, you must set the function back to automatic control, so that the controller continues to operate as before.



Operation | Ventilation equipment card | View details

Provide access to manual control of the climate equipment.



Settings | Technical | Manual/auto | Manuel Mode

Lists all components currently set to manual mode.

The manual mode can also be deactivated here.

4.2 Temperature

The controller adjusts the inside temperature according to the **Temperature setpoint**.

When the inside temperature is too high, the controller increases the ventilation level to supply more fresh air and cool the air if needed. When the inside temperature is too low, the controller reduces the ventilation level to keep the heat in the house. The heating level is increased if needed.

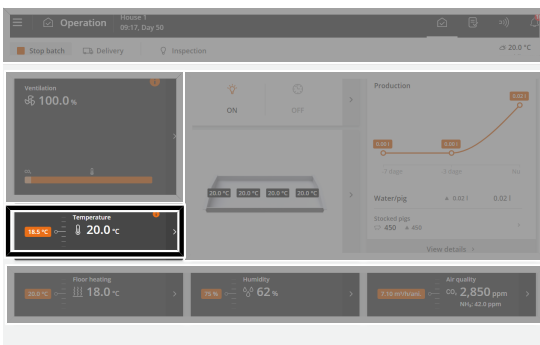
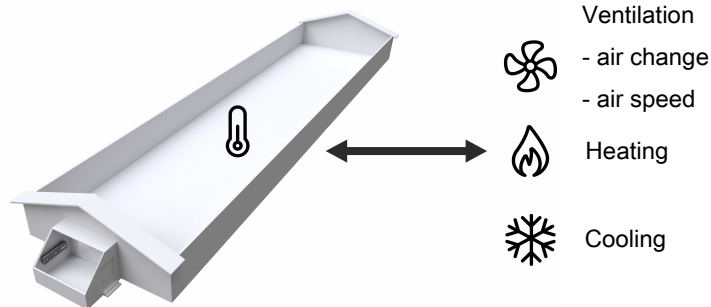

Operation. The most important temperature values can be viewed and adjusted via the card **Temperature**.

The front of the card shows the current inside temperature and the temperature setpoint.

The following sections describe the functions and setting options available for temperature.

4.2.1 Temperature control

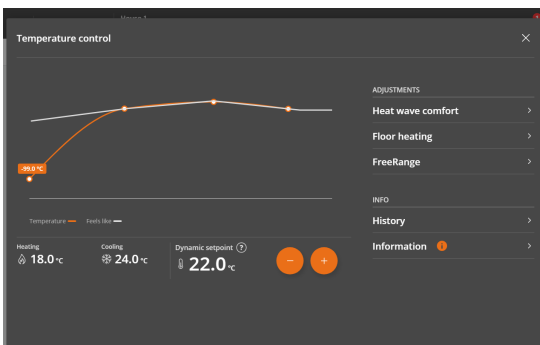

Operation | Temperature card

The temperature card provides access to easy adjustment of the inside temperature during a batch. This is done via the function **Dynamic setpoint**.

When the inside temperature is desired to increase or decrease, the **Dynamic setpoint** is adjusted up or down by 0.5 °C. Wait approximately 2 hours and evaluate the status.

Dynamic setpoint continuously takes account of both the current ventilation and the settings you make. It will thus adapt so that there is always the optimum temperature at the given level of ventilation.

The **Temperature** card provides furthermore access to following temperature related functions:

- Settings for heat wave comfort. See the section Heat wave comfort.
- Settings for stand-alone heating. See the section Stand-alone heating [▶ 80].
- Settings for floor heating. See the section Floor heating [▶ 80].
- Graphic history curve. See the section History curves.

When determining the desired temperature strategy, the following parameters are taken into account:

☰ Menu button | 📄 Strategy | 🌡️ Climate | 📌 Temperature.

Inside temperature	Setting of batch curves for Inside temperature , Heat offset and Stand-alone heating . See also the sections House heaters [▶ 78] and Stand-alone heating [▶ 80].
Comfort temperature	See the section Comfort temperature [▶ 30].
Floor heating	See the section Floor heating [▶ 80].

4.2.1.1 Two-zone control

Batch curve settings via Strategy

Front and Rear have the same setting by default at two-zone control, as the batch curve is common to both zones. The settings are changed with the same value in both zones via the batch curve (**Operation | Strategy | Temperature**).

However, it is also possible to make a setting in each zone separately by adjusting via, for instance, **Temperature setpoint**.

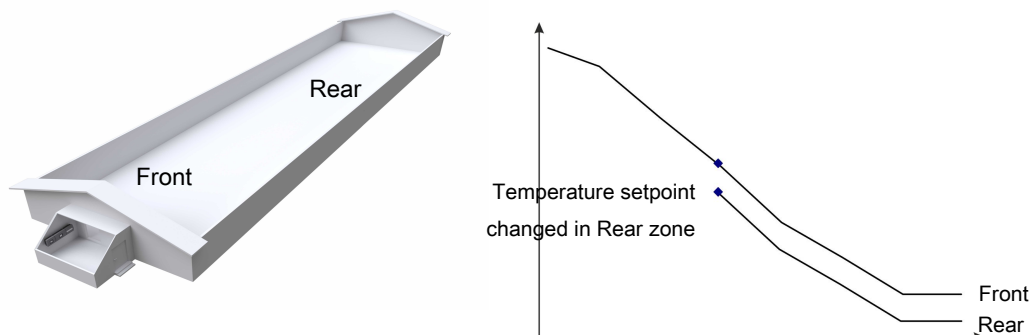

Figure 4: For example, if you want to change the temperature setting in one zone or change it by a different number of degrees in each zone, you must do it through **Temperature setpoint**.

4.2.1.2 Heat wave comfort

A heat wave is a period of high outside temperatures both day and night. After a heat wave, it is important to ensure that the animals do not get too low a temperature too quickly, as this can increase the risk of them becoming ill.

The heat wave comfort function adds an addition to the set temperature to postpone the time when ventilation starts again due to a high inside temperature. See also the section Comfort temperature [▶ 30].

☑️ Menu button | 📄 Temperature card | 🌡️ Heat wave comfort.

Heat wave:	Showing whether the conditions for a heat wave are present or not.
Heat wave comfort active	Connection and disconnection of the function.
Outside temperature limit	The setting of the outdoor day and night temperature to make it a heat wave.
Activation time	The setting of the amount of time the outdoor temperature must have exceeded the heat wave limit before the feature is activated.

Comfort reduction factor	The setting a factor that determines how quickly the comfort temperature is to be cleared (°C/hour). The higher the factor, the faster the comfort temperature is cleared.
Heat wave ending time	Display of how many hours a heat wave comfort addition is still added to the temperature setpoint. The ending time is changed by changing the Comfort reduction factor.

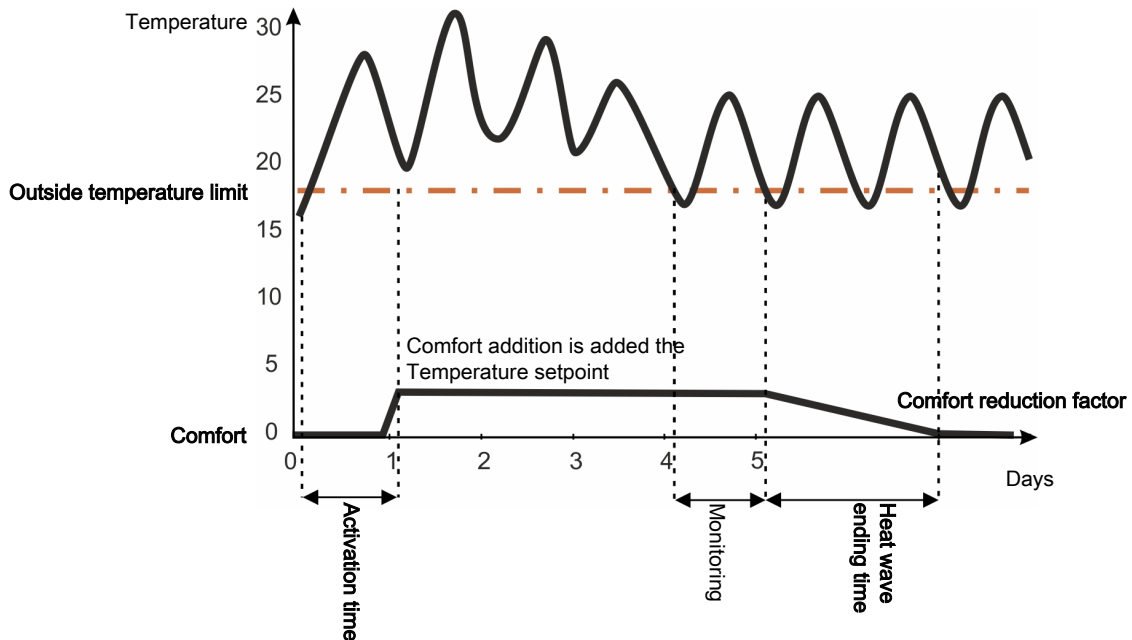

Figure 5: Heat wave comfort

During the heat wave, the comfort temperature is maintained.

When the heat wave stops, the controller monitors the outside temperature for 24 hours and the comfort addition is gradually reduced over a few days.

For example, with a reduction factor of 0.06 °C/hour, it will last 50 hours until the full comfort temperature is cleared.

4.2.1.3 Comfort temperature

Not relevant for Tunnel and Natural.

If the controller increases the ventilation on hot days to keep the inside temperature down, the higher air velocity in the house will make the air feel cooler for the animals. Thus, for example, 20°C feels warmer on a calm day than 20°C in windy weather conditions.

The controller lets the inside temperature increase by the set comfort temperature before it increases the ventilation. The temperature increase counteracts the fact that the animals perceive the powerful ventilation as a draft.

☰ Menu button | 📄 Strategy | 🌡️ Temperature

Comfort temperature	Setting of a number of degrees that the inside temperature must rise to compensate for the chill effect that the animals are exposed to at a high ventilation level.
----------------------------	--

Batch production

The comfort temperature can, at batch production, be set as a curve over 2 days. Thus, the controller will gradually reduce the temperature addition and raise the ventilation degree that activates comfort as the animals grow bigger.

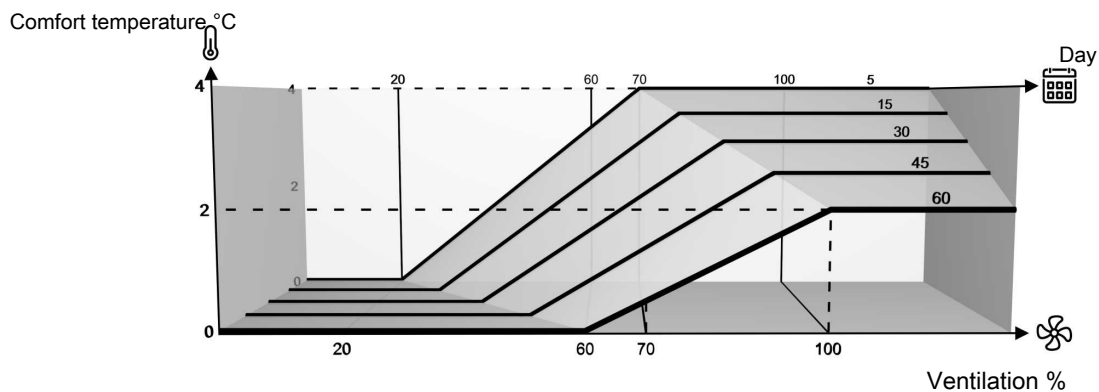

Figure 6: Comfort temperature at batch production

At batch production, the comfort temperature is, by default, set to start as an addition of 4°C at a ventilation rate of 30%. Toward day 60, it gradually changes to 2°C at a ventilation rate of 50%.

Continuous production

At continuous production, the comfort temperature is, by default, set as an addition of 2°C, which is gradually added to the **Temperature setpoint**, when ventilating more than 50%.

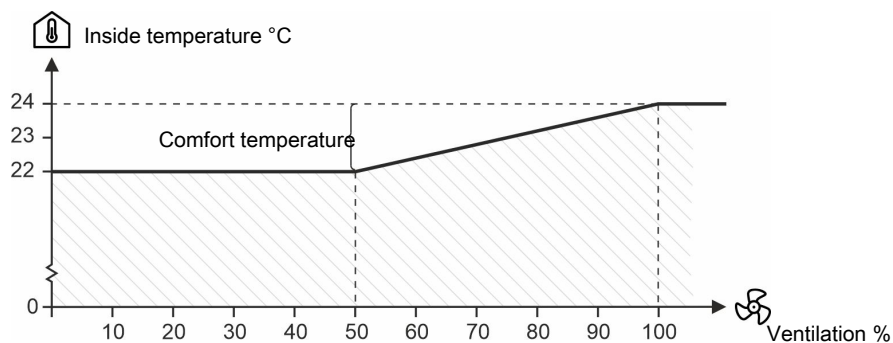

Figure 7: Comfort temperature at continuous production

4.2.1.4 Day and night adjustment

Day and night adjustment is intended for changing the inside temperature over a set period every 24 hours in order to support the animals normal behavior. A lower inside temperature will make the animals experience a normal circadian rhythm. Furthermore, the ventilation level will be relatively higher, thus ensuring a better air quality.

Day and night adjustment cannot be activated when the house is set to **Empty house**.

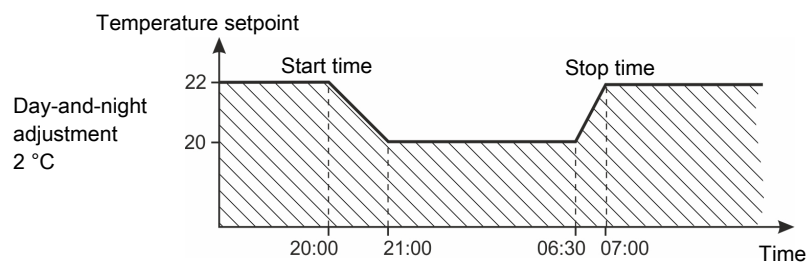

Figure 8: Day and night adjustment set as a nightly lowering of temperature.

The inside temperature will gradually adapt to day and night adjustments within the period the reduction in temperature is set to last.

**Operation | Program overview card | Day and night adjustment.**

Start	Time when the day and night adjustment starts.
Stop	Time when the day and night adjustment stops.
Temperature adjustment	Setting of the number of degrees by which the inside temperature will change in relation to the temperature setpoint. Use this option to make an adjustment that is independent of the batch curve.



Menu button |

**Strategy |****Temperature.**

Day and night adjustment	Setting of the number of degrees by which the inside temperature will change in relation to the temperature setpoint. At batch production, the function can be set as a batch curve over 6 day numbers. Thus, the controller will gradually change the temperature day and night adjustment as the animals get bigger.
---------------------------------	---

This function is designed for a nightly temperature setback but can be set for running at any time and for letting the temperature rise (by setting the value at a positive figure).

4.3 Humidity

The air humidity in the house is important for the indoor climate and the animals' well-being. Concerning air humidity, the regulation must ensure a suitable level - neither too high nor too low.

When the animals are young, it is especially important to avoid a very high humidity level (> 80%) to reduce the pathogens in their immediate environment. A very low humidity level (<40%) can dry out the house, and the animals.

Concerning animal welfare, it is generally more important to keep the correct inside temperature than to keep the humidity within a precise level. Therefore, the controller regulates humidity only when the temperature control allows it.



Note that a high inside temperature and high air humidity (>85%) can be life-threatening to the animals.

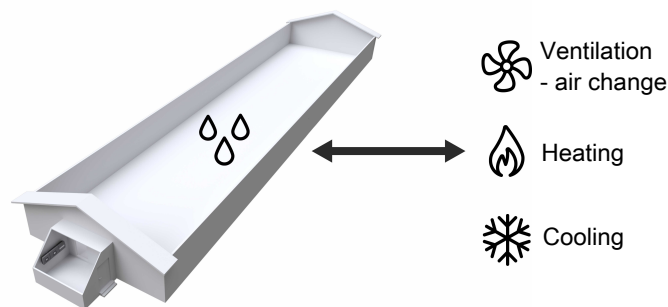

Humidity is supplied to the housing air partly from the animals, feed, drinking water, and litter and partly from the cooling and humidification functions.

Basically, the humidity in the house can be regulated by increasing or decreasing the ventilation level or increasing or decreasing the heat supply. The controller has several humidity control principles, which you can choose from, depending on what suits the house in question. See the section Humidity control mode [▶ 35].



Operation. The most important humidity values can be viewed and adjusted via the card **Humidity**.

The front of the card shows the current inside humidity and the desired air humidity.

The following sections describe the functions and setting options available for humidity.

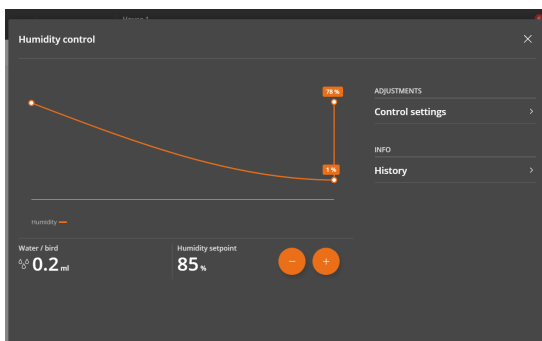

Operation | Humidity card

The humidity card provides easy adjustment of the upper inside humidity limit during a batch.

If you need to adjust the humidity, changing it 3% and waiting 3-4 days is recommended. Then assess whether a further adjustment is necessary.

The Humidity card shows a curve of the humidity development during the last 2 days and a key value for water consumption calculated as water/animal. It may indicate problems such as water pressure or leakage on piping strings if water consumption is so high that it exceeds the reference.

The humidity card also provides access to the following humidity-related settings.

 **Operation | Humidity card | Control settings**

Humidity control enabled	<p>Connection and disconnection of humidity control.</p> <p>When the humidity control is disconnected, the controller regulates the ventilation exclusively in relation to the inside temperature.</p> <p>Switching off the humidity control during certain outdoor climate conditions may be relevant. It applies to areas with high outside humidity and temperature for a long time. Here, however, the humidity control will have no effect. See also the section Intelligent humidity control - at high outside temperature and outside humidity [▶ 37].</p>
Humidity control mode	<p>Selecting type of humidity control. See also the section Humidity control mode [▶ 35].</p>
Maximum humidity ventilation	<p>At Humidity heat. Setting of the degree of ventilation where the heat is reduced.</p> <p>In the case of humidity ventilation. Setting of the degree of ventilation where the humidity ventilation stops. See also the section Humidity ventilation [▶ 36].</p> <p>If you, e.g., in periods of high outside humidity and temperature, want to limit the humidity ventilation, this setting can be reduced.</p>
Humidification setpoint	<p>Setting of lower air humidity limit.</p> <p>Can be set to a maximum of 5% below Humidity. See also the section Humidification [▶ 35].</p>
Humidification last day	<p>Setting of the day number when the controller deactivates humidification.</p>
Switch humidity control on batch day	<p>Changing the humidity control mode during the batch can be advantageous as the animals' needs change with age. Changing the humidity control mode automatically on a specific batch day is possible.</p> <p>Select the humidity control mode to start with and the mode to switch to and select the day for the switch to take place.</p>
Switch humidity control setup	<p>Selection of the humidity control principle the batch should switch to and selection of the day number where the change takes place.</p>
Adaptive reaction	<p>Setting how quickly the adjustment should react at adaptive humidity control (at Humidity ventilation and Humidity heat only).</p> <p>From the factory, the control is set to adaptive control. It means that the controller continuously adapts the regulation to the current conditions. Thus, there is less need for the user to make manual changes to settings. Also, see the Technical Manual.</p>
Humidity control status	<p>Display of the current humidity control. (at intelligent humidity control only)</p> <p>See the section Intelligent humidity control - at high outside temperature and outside humidity [▶ 37].</p>

When determining the desired temperature strategy, the following parameters are taken into account:

See also the section  Strategy [▶ 22].

 Menu button |  **Strategy | Climate |**  **humidity**

Humidity	<p>The curve values must be set to suit the production method, type of animal, and the area's climate - especially outside humidity.</p>
Humidification	
Maximum humidity ventilation	

4.3.1 Humidification

Humidification increases the air humidity of the house by supplying atomized water to the air. It is important to maintain a certain air humidity, among other things to prevent dehydration of the animals' mucous membranes. The controller increases humidification as long as the air humidity is below the humidification setpoint. During batch production, the controller can automatically regulate the humidification in relation to the age of the animals by adjusting the batch curve. See also the section [Strategy \[▶ 22\]](#).

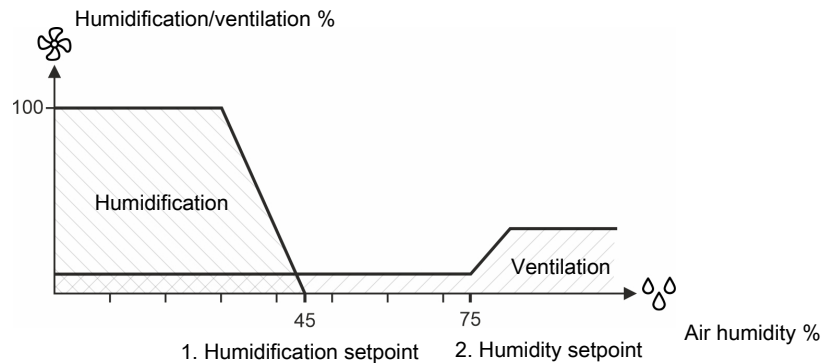

Figure 9: 1. Decreasing air humidity. The air humidity is below Humidification setpoint. The controller starts the humidification. 2. Increasing air humidity The air humidity is above humidity setpoint. The controller increases the ventilation.

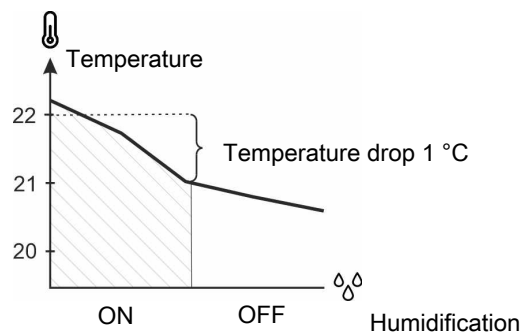

Figure 10: Decreasing temperature: Humidification will be disconnected if the inside temperature is 1° C below Temperature setpoint. Humidification could otherwise make the inside temperature drop further.

4.3.2 Humidity control mode

The air humidity can be regulated based on the correlation between the air temperature and its ability to contain moisture. The warmer the air is, the more water vapor it can contain.

It is generally estimated that for every 1 °C temperature change, the humidity will change 5%.

- As the temperature rises, the relative humidity decreases.
- As the temperature falls, the relative humidity increases.

If the temperature falls so much that the relative air humidity reaches 100%, the water vapor will start to condense (dew point).

These general principles can be exploited by choosing the humidity control mode that best suits the requirements of the animals and the individual house (geographical location).

The controller has 3 primary humidity control modes, each of which takes its own area into account.

Temperature reduction	Humidity ventilation	Humidity heating
Animals	Litter quality	Air quality (CO ₂)

4.3.2.1 Humidity ventilation

This function is not active at tunnel ventilation.

Consequences	Method of operation
Higher heat consumption Maintains the set humidity	Increases ventilation. The humidity is ventilated out of the house. When the temperature drops, the heat is increased in order to maintain the inside temperature.

When the controller has been set to control humidity according to the humidity ventilation principle, it will reduce a too high humidity level by gradually increasing the ventilation. The increased air change will make the inside temperature fall. To maintain the temperature of heating temperature, the heating system will gradually supply more heating.

Humidity ventilation makes it possible to keep the house air humidity at the set humidity.

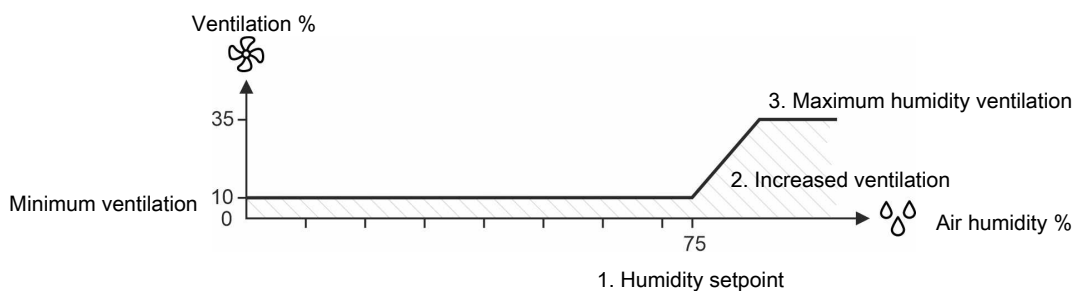

Figure 11: Humidity ventilation: 1. The air humidity exceeds humidity setpoint. 2. The controller increases ventilation. 3. Increase up to maximum humidity ventilation (35%).

Maximum humidity ventilation can be set with a batch curve. This especially relevant to livestock houses with limited heating capacity where you would prefer a lower degree of humidity ventilation at the start of a batch when the animals are small.

4.3.2.2 Temperature reduction

The controller can control the house humidity according to the humidity control principle with temperature reduction when the animals can tolerate a temperature drop at high air humidity. This function limits the use of heating in the house but cannot keep the air humidity at the humidity setpoint.

Consequences	Method of operation
Less heat consumption Possible to regulate humidity without heat Does not maintain the set humidity The animals must be able to tolerate the temperature drop at high humidity.	The inside temperature that is controlled as it is reduced so that ventilation can be increased.

Temperature reduction with heat supply

When the controller is set to control humidity according to the temperature reduction principle, the controller will adjust a too high humidity level by reducing the inside temperature by a few degrees (reduction).

At a lower temperature setting, the controller will thus increase ventilation and consequently the change of air. When this has made the inside temperature drop, ventilation will decrease to minimum ventilation in order to limit the heat loss from the ventilation.

If this is insufficient to maintain the reduced House heater setpoint, the controller will gradually supply more heat.

Temperature reduction without heat supply

The humidity control process is the same as for heat supply until the point at which ventilation is reduced to minimum ventilation. Without heat supply, the inside temperature could continue to drop below the **Heater setpoint**.

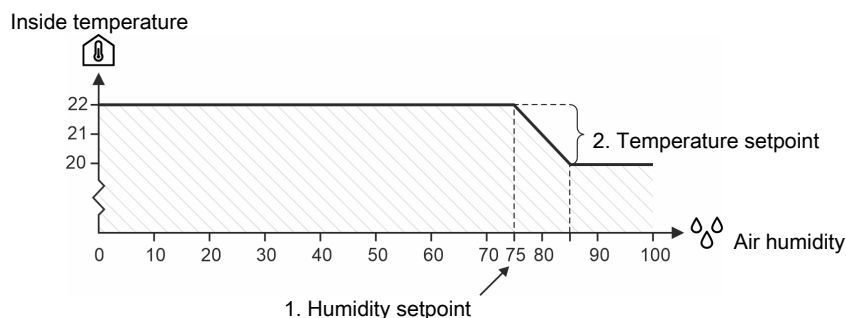

Figure 12: Humidity control with temperature reduction

The controller will lower the set temperature by 1° C each time the air humidity exceeds the humidity setpoint by 5 %.

4.3.2.3 Humidity heat

When the controller has been set to control humidity according to the humidity heat principle, it will reduce a too high humidity level by gradually increasing the heat supply. The increased heat supply will make the inside temperature rise. In order to maintain the temperature, the ventilation system will gradually increase ventilation.

Humid heat makes it possible to keep the house air humidity at the set humidity.

Consequences	Method of operation
Highest heat consumption	Increases heat supply.
Maintains the set humidity	Humidity and heat are removed through ventilation when the temperature gets too high.

Heating costs

- Check the heat consumption at regular intervals when using the principle of humidity heating to regulate the house humidity. Settings for heating and humidity control should be checked to avoid excessive heating costs.

At high outside temperature and high outside air humidity

- Heat management according to humidity will not provide better litter or air quality. Increased ventilation will basically draw as much humidity into the house as is ventilated out.

4.3.3 Intelligent humidity control - at high outside temperature and outside humidity

As an alternative to the standard setup of the controller, the humidity control can be changed so that high air humidity in the livestock house is reduced by raising the inside temperature.

The intelligent humidity control regulates both the inside and outside temperature and the inside and outside humidity, optimizing the humidity control according to the current climate conditions.

It is intended for areas with high outside temperatures and humidity where humidity control at high humidity through increased ventilation is less suitable.

The function can be used in two ways:

- Stop the standard humidity control (well-suited for broilers).
- Stop the standard humidity control and increase the temperature setpoint (well suited for layers).

The intelligent humidity control takes over when the following conditions are met:

1. High inside humidity (higher than Humidity setpoint)

2. High outside humidity (exceeds the limit for Outside humidity)
3. High outside temperature (higher than the Temperature setpoint of 6°C)

Example values for when Intelligent humidity control takes over

Current conditions	Conditions	
Inside humidity 85%	1. High inside humidity	85% > 75%
Humidity setpoint 75%	2. High outside humidity	82% > 80%
Outside humidity 82%	3. High outside temperature	17°C > (19°C - 6°C)
Outside temperature 17°C		
Temperature setpoint 19°C		

Operation | Temperature card | Dynamic setpoint

Increase by humidity

View of how much the temperature setpoint is increased due to humidity.

The maximum temperature increase is 3°C, which is equivalent to a humidity reduction of 15%

A rule of thumb states that for every 5%, the humidity is reduced, the temperature rises by 1°C.

Operation | Humidity card | Control settings | Status for humidity control

Inside humidity above setpoint

The menus show how the current values are relative to the setpoints.

Outside humidity is above/below the limit

This way, one gains insight into how close the regulation is from switching.

Outside temperature is above/below the limit

This function is only available when an outside and inside humidity sensor is installed.

4.3.4 Humidity settings

4.3.4.1 Adaptive humidity ventilation

Big Dutchman recommends that humidity control is set up to adaptive control.

When using adaptive control, it is possible to fine-tune how quickly it reacts when the conditions change.

Operation | Humidity card | Control settings

Adaptive reaction for ventilation

Setting how quickly the adjustment should react (**Fast/Medium/Slow**).

It is not necessary to change the factory setting **Medium** unless the adjustment reacts too slowly (select **Fast**) or too fast (select **Slow**). It will depend on the system in question.

Also, see the Adaptive control section of the Technical Manual.

4.3.4.2 Adaptive humidity heat

Big Dutchman recommends that humidity control is set up to adaptive control.

When using adaptive control, it is possible to fine-tune how quickly it reacts when the conditions change.

Operation | Humidity card | Control settings

Adaptive reaction for heat

Setting how quickly the adjustment should react (**Fast/Medium/Slow**).

It is not necessary to change the factory setting **Medium** unless the adjustment reacts too slowly (select **Fast**) or too fast (select **Slow**). It will depend on the system in question.

Also, see the Adaptive control section of the Technical Manual.

4.4 Ventilation

The house ventilation consists of air inlets and air outlets. Apart from supplying fresh air to the house, ventilation is to remove humidity and excess heat, if any.

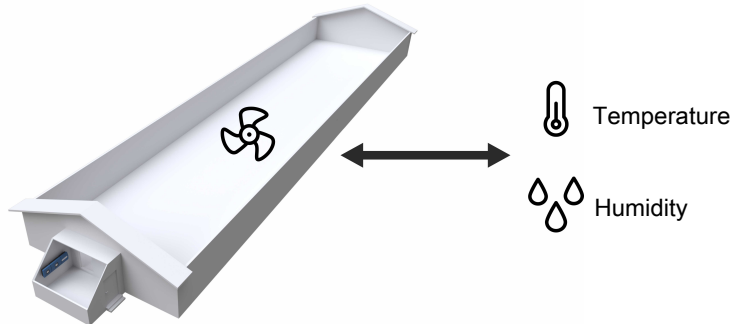

The degree of ventilation is determined based on 3 parameters:

1. Air quality (minimum ventilation). The amount of ventilation needed to ensure good air quality (CO₂).
2. Variable ventilation. The amount of ventilation needed to remove humidity and excess heat.
3. Maximum ventilation. The maximum degree of ventilation that must be used to remove humidity and excess heat - it typically depends on the age of the animals.

The controller continuously adjusts the ventilation according to a calculation of the ventilation requirement. Depending on the type of ventilation system, the controller calculates the ventilation requirement based on temperature and air humidity. Thus, the controller will increase or limit ventilation according to whether the inside temperature and air humidity are too high or too low.

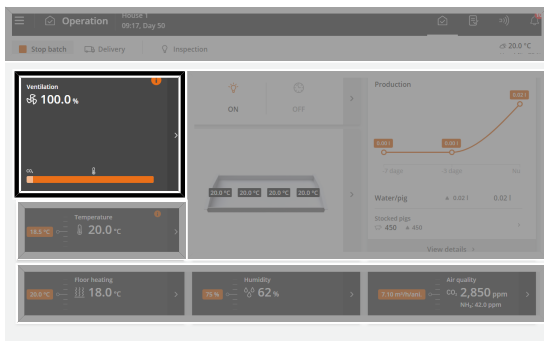

Operation. The most important ventilation values can be viewed and adjusted via the card **Climate equipment**.

The front of the card shows how the ventilation system is running right now. It applies to the active equipment and the active functions.

The **Climate equipment** card allows you to adjust the values that are valid on the current day. The adjustment applies to the rest of the batch but is reset at the batch end. A new batch starts with the values from the batch curves under **Strategy**.

The number of animals in the house must be correct to achieve correct ventilation.

Please also note that at two-zone ventilation, the animals are assumed to be distributed equally in the 2 zones.

The following sections describe the general functions and setting options available for ventilation. Next, each type of ventilation system is described separately.

- Side (LPV). See the section Side ventilation [▶ 43].
- Tunnel. See the section Tunnel ventilation [▶ 47].
- Combi-Tunnel. See the section Combi-Tunnel ventilation [▶ 50].
- Natural. See the section Natural ventilation [▶ 51].

4.4.1 Air quality

The **Air quality** function provides just the amount of air to the house, which ensures acceptable air quality. The function is particularly relevant in periods with cold weather when it is not necessary to ventilate to keep down the inside temperature.

The controller can regulate the air quality as minimum ventilation ($\text{m}^3/\text{h}/\text{animal}$) or as CO_2 ventilation (ppm) (using a CO_2 sensor).



Operation | Air quality card

The air quality card provides access to easy adjustment of the air quality during a batch.

The front of the card displays the desired ventilation and the current CO_2 level, if needed. When a NH_3 sensor is connected, the current NH_3 level is also displayed.



If the air quality is poor or if the temperature is too low

Adjust the setting up or down and wait and reevaluate the status the next morning.

The Air quality card shows a development curve for the last 24 hours.

The Air quality card provides access to the following functions:

- Settings.
- Graphic history curve (with CO_2 sensor CO_2 level is displayed. Without sensor, minimum ventilation is displayed).
- Information. See the section Informationskort [▶ 13].

When determining the desired air quality strategy, the following parameters are taken into account:

Menu button | Strategy | Climate | CO_2 Air quality

Air quality control	Select whether the air quality is to be regulated based on minimum ventilation (m^3/h per animal) or based on CO_2 ventilation (CO_2 level of the air).
Use NH_3 ventilation	Select whether to use an NH_3 sensor to monitor the NH_3 level (ammonia) in the house as an indicator of the air quality. See also the section NH_3 [▶ 42].
CO_2 ventilation	Using a CO_2 sensor, the CO_2 level in the livestock house can be monitored and used as an indicator of the air quality. The function either increases or decreases the ventilation depending on the atmospheric CO_2 content. i.e., whether it is higher or lower than the CO_2 setpoint. If the inside temperature drops below the heating temperature setpoint, the climate controller reduces the CO_2 ventilation by up to 25%. <i>Before Day 10</i> the controller can limit the CO_2 ventilation to 0%. <i>After Day 10</i> the controller cannot limit the CO_2 ventilation to less than 25% of the minimum ventilation.
Minimum ventilation	Setting a lower limit for how little is ventilated in relation to the animals' air requirement ($\text{m}^3/\text{h}/\text{animal}$). The animals' fresh air requirement varies according to breed and weight. Enter the requirement as $\text{m}^3/\text{h}/\text{animal}$. The correct number can be found in the technical literature or by asking an advisor. Minimum ventilation must only be adjusted in relation to the desired air quality - not to regulate the inside temperature.

From the factory, the limit for CO₂ is set based on the goal that the CO₂ level in the house must not exceed 3,000-3,500 ppm.

It is important that the batch curve is adapted according to the animal type, local regulatory requirements (in the EU max. 3000 ppm), outside climate conditions and type of heat supply.

When setting batch curves:

- Note that the number of animals must be correct.
- Note that in the case of heat supply with direct combustion, where combustion gas is led out into the house itself (e.g., gas and oil burners without a chimney), a higher minimum ventilation will be required.
- Note that a high minimum ventilation results in increased heat consumption.



Lack of ventilation in the case of CO₂ alarm

In the case of CO₂ sensor errors or high CO₂ alarm, the controller deactivates the CO₂ function and enables Minimum ventilation. It is to prevent a defective CO₂ sensor causing a too low or too high ventilation level.

It is therefore essential that Minimum ventilation and Number of animals are correctly set, even when using CO₂ minimum ventilation.

4.4.1.1 Cycle timer at minimum ventilation

If there is a very limited need for ventilation, you can control the air flows in the house with the cycle timer function.

When the controller regulates minimum ventilation with cycle timer, the air inlets are alternately opened and closed briefly. This sends a stronger jet of air through the house, which ensures a thorough replacement of the housing air.

When the cycle timer function is active, the graphical status is displayed on the **Climate equipment** card.

See also the technical manual regarding **Minimum air intake**.

4.4.1.2 NH₃

By using a NH₃ sensor, the current NH₃ level (ammonia) in the house can be monitored and used as an indicator of the air quality.

This function increases the ventilation and the current ventilation level depending on the air's NH₃ content, that is if it is higher than the NH₃ setpoint. Ventilation due to NH₃ can, however, not exceed 25% of the ventilation.



Operation. The most important NH₃ values can be viewed and adjusted the CO₂ card.

The front of the card shows the current NH₃ content in the air.

The following sections describe the functions and setting options available in the NH₃ menu.



Operation | Air quality card | NH₃ control

NH₃	Current NH ₃ level.
Apply NH₃ ventilation	You can connect and disconnect the NH ₃ ventilation function.
NH₃ setpoint	The upper limit of NH ₃ in the air.

When the NH_3 content in the air exceeds the NH_3 setpoint, the function increases the ventilation.

If the inside temperature drops below the heating setpoint, the climate controller will gradually reduce the NH_3 ventilation.

! Incorrectly NH_3 setpoint

- Note the setting of the NH_3 setpoint.

As long as the NH_3 level is above the setpoint, the controller will increase the ventilation to reduce the level.

A too low setting can result in very high heat consumption or a temperature drop in the livestock house if there is no heat supply available.

4.4.2 Side ventilation

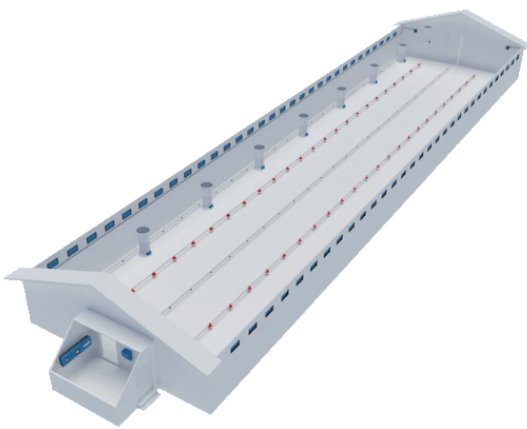

(LPV - Low Power Ventilation)

An LPC system is a classic negative pressure system. The system is intended for temperate regions of the world and can be adapted to most house types.

In an LPV system, the wall, ceiling or roof inlets supply the fresh air. The system adapts automatically the ventilation to the temperature outside, production type and the age of the animals.

When it is cold outside, the fresh air mixes with the housing air before it reaches the area occupied by the animals.

In hot periods, the air is taken in the same way, but the air is drawn into the house at a higher speed. This results in air circulation around the animals, and they are cooled without perceiving the increased air circulation as a draft.

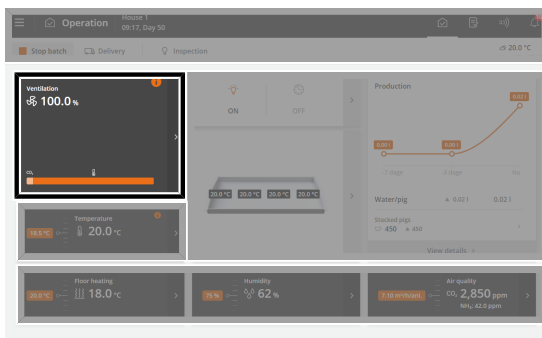

Operation | Climate equipment card

The current status values for side ventilation can be viewed via the **Climate equipment card**.

The card displays the current ventilation requirement (%) and how much of the ventilation is due to temperature and humidity.

The climate equipment card provides furthermore access to following views:

- View of air inlet requirement.
- Graphic history curve.

4.4.2.1 Ventilation settings

Maximum ventilation

Maximum ventilation sets a limit to how much of the capacity of the ventilation system (in percentage) the controller can activate.

The function can be relevant to use at very high outside temperatures, i.e. in periods when the outside temperature daily exceeds 30-35 °C. Ventilation with the entire capacity of the system will here cause the inside temperature to exceed the desired temperature, as large amounts of hot air are supplied. The function can also prevent young animals from being exposed to a level of ventilation which they do not tolerate.

Maximum ventilation is typically only used in houses with high-pressure cooling and side ventilation and only in the summer months, where the cooling potential is great.

It is important that the **Maximum ventilation** is removed when the outside climate changes. The controller does not take the cooling potential into account over the year.

	Summer	Winter
Limitation	Yes (> 30-35 °C)	No
Setting	Batch curve	500 %

☰ Menu button | 📄 Strategy | 🌡️ Climate | 🌀 Ventilation

Maximum ventilation Setting of upper limit for how much of the system's capacity the controller can activate.
 100% ventilation corresponds to the animals' calculated requirement, while ventilation utilizing the total system capacity may reach e.g. 160% (see also the section on extra ventilation).

4.4.2.1.1 Inlet de-ice

De-icing is a function that changes the regulation of ventilation at low outside temperatures to cycle time in order to avoid ice formation in the air inlet.

The controller activates de-icing when the outside temperature falls below the setting for **Inlet de-ice below outside temperature**.

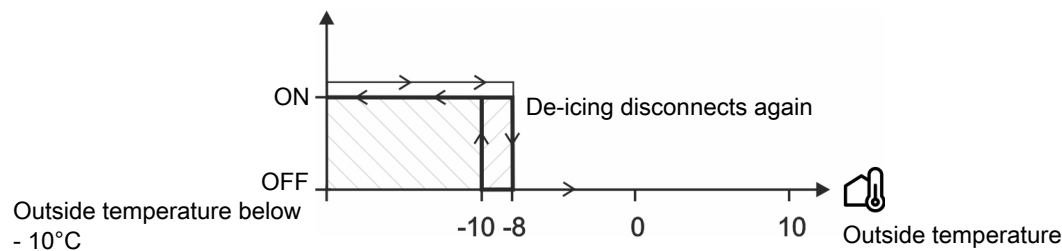

Figure 13: Activation of de-icing

🏠 Operation | 📄 Climate equipment card | 🌀 Air inlet

Inlet de-ice below outside temperature Setting of a lower limit for the outside temperature. If the outside temperature drops below the lower limit, the controller activates the de-icing function.

4.4.2.1.2 Heat recovery unit

The availability of the functions described depends on the structure of the heat recovery unit in question.

The heat recovery unit can be controlled as an integrated part of the house ventilation system. It is used to recover heat in the low ventilation area for a number of days at the beginning of a batch. When a higher air output is needed than the capacity of the heat recovery unit, the ordinary ventilation system will gradually take over.

The heat recovery unit has two fans. One of the fans removes warm, humid air from the house. The other fan draws fresh, preheated air into the house.

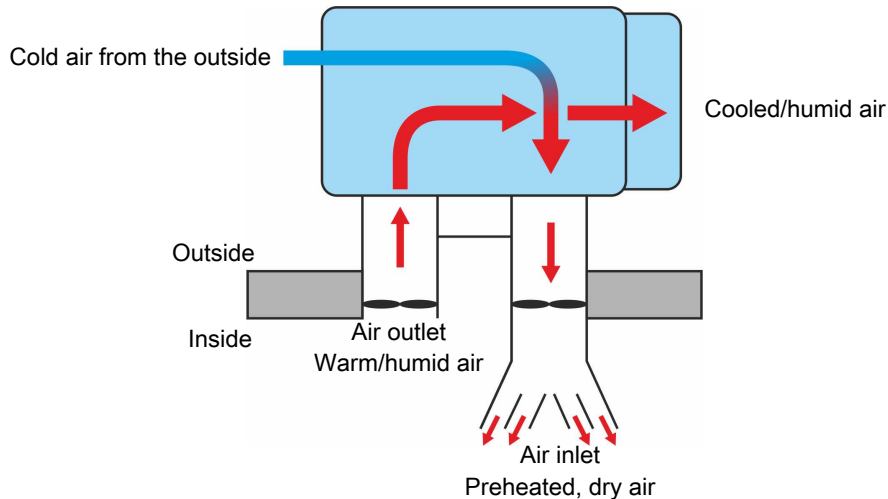

Figure 14: Example of heat recovery unit principle.

Operation | Climate equipment card | Heat recovery unit

Heat recovery unit efficiency	View of the efficiency, indicating how much the air in the inlet is heated in relation to the outside temperature. The value should be taken as an estimate as it is based on the average temperature of the air in the air intake.
Heat recovery unit power recovery	View of the calculated value of how much energy is currently being recovered (power). The value should be taken as an estimate as it is based on estimated values of air volume and average temperature of the air in the air intake.
Heat recovery unit	The heat recovery unit's current air output shown as a percentage of total output.
Activate heat recovery unit	Connection and disconnection of heat recovery unit. When the heat recovery unit is disconnected, the other components of the ventilation system take over.

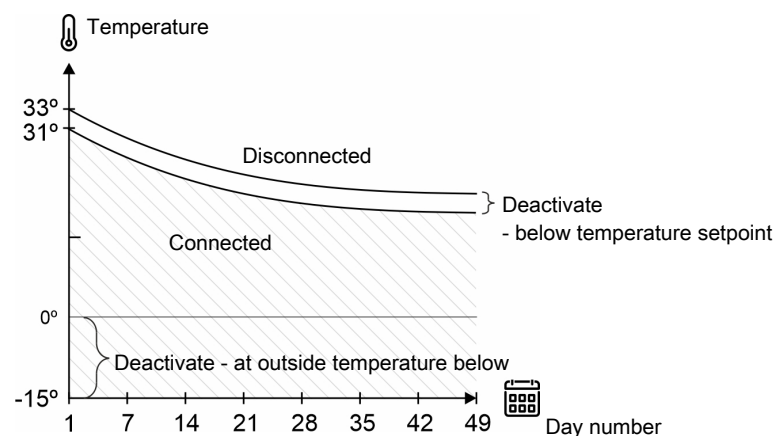

Figure 15: Heat recovery unit – low and high outside temperature limits

Menu button | Strategy | Heat recovery unit

Low outside temperature limit enable	Connection- and disconnection of the heat recovery unit in the event of low outside temperature. The purpose of this function is to prevent the heat recovery unit from icing at very low outside temperatures.
Outside temperature	Display of the current outside temperature.
Allow heat recovery unit	Setting the outside temperature at which the heat recovery unit engages.
Abandon heat recovery unit	Setting the outside temperature at which the heat recovery unit disconnects.
High outside temperature limit enable	<p>Connection and disconnection of heat recovery unit at high outside temperature. The purpose of this function is to prevent the heat recovery unit from running when the difference between the outside and inside temperatures is too small for heat recovery to be effective.</p> <p>The heat recovery unit disables when the outside temperature gets close to the temperature setpoint. Set the number of degrees for the minimum difference between outside and inside temperature</p>
Disable heat recovery unit below set point	Setting degrees. When the outside temperature is closer to the temperature setpoint than the set degrees, the heat recovery unit disconnects.

Anti-icing function

 Menu button |  Strategy |  Heat recovery unit

Anti-ice	<p>View of whether the function is active or not.</p> <p>When the anti-ice function is active, the air inlet of the heat recovery unit alternately turns on and off to prevent ice from forming in the unit.</p>
Anti ice active at outside temperature below	Setting the outside temperature which activates the anti-ice function.
Activate heat	Connection and disconnection of an external heat source in connection with the heat recovery unit.

Cleaning program

 Operation | Program overview card | Heat recovery unit cleaning

Cleaning programs	<p>When the heat recovery unit used has a built-in cleaning system, the controller can run up to three cleaning programs per 24 hours.</p> <p>Setting of number of cleaning programs per 24 hours.</p> <p>Setting the start and stop times for the cleaning programs.</p>
Info	Status views of the heat recovery unit's individual parts.

4.4.3 Tunnel ventilation

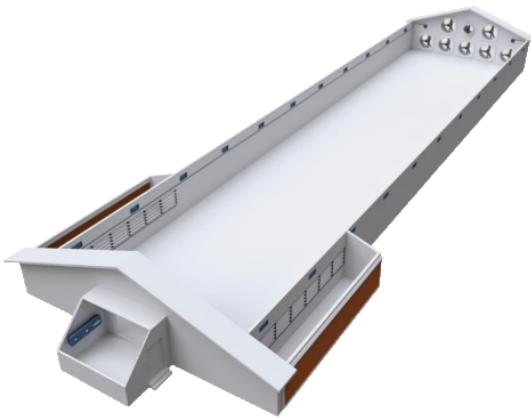

Tunnel houses are intended for tropical regions of the world, where it is constantly hot, and it is therefore important to lower the temperature in the house.

Heat and very humid conditions are best solved with high air speed.

When using tunnel ventilation, large air volume and air movement can remove heat from the animals.

The air intake is located in the sides or in one gable and is often equipped with cooling pads or high-pressure cooling, in order to cool the incoming air.

At the end of the house, which is opposite the air intake, large gable fans are placed for air outlet. This creates a cooling air-flow in the longitudinal direction of the house - a so-called chill effect.

The chill effect is a reduction in the perceived temperature as a result of air movement.

Depending on air humidity, it is possible to lower the temperature significantly.

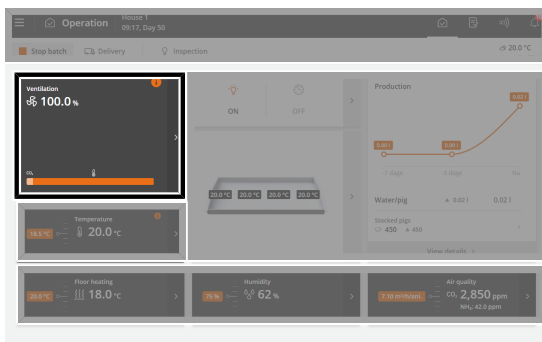

Operation | Climate equipment card

The most important ventilation values can be viewed and adjusted via the card **Climate equipment**.

The graph on the card displays the current ventilation requirement (%) and how much of the ventilation is due to temperature and humidity respectively, and what the air velocity is (m/s).

Furthermore, the card shows the calculated air velocity (meter/sec.).

The current air velocity is a calculated value. Based on the cross-sectional area of the house and the actual capacity of the tunnel fans, the controller calculates the actual air velocity down through the house.

The climate equipment card provides furthermore access to following tunnel related views:

- View of air inlet requirement.
- Graphic history curve.

The following sections describe the functions and setting options available for tunnel ventilation.

Operation | Climate equipment card | Air outlet | Tunnel

Stop speed cycle timer

Cycle timer is used to be able to ventilate with limited air velocity and at the same time maintain a good air change throughout the house.

Setting the maximum air velocity acceptable when tunnel ventilation is running according to the cycle timer. Above this level, ordinary tunnel ventilation without cycle timer is used to ventilate.

See also the section Cycle timer at tunnel ventilation [▶ 48].

Maximum air speed

Setting the lowest air velocity acceptable in tunnel ventilation.

At high air velocity, there is a risk of excessive ventilation. Therefore, it is possible to set an upper limit for the air velocity.

Possible max. air speed	Display of the maximum air speed of the ventilation system.
Next change:	Display of the time until the flap position changes the next time. When the controller regulates minimum ventilation with cycle timer, the flaps alternately open and close.

☰ Menu button | 📄 Strategy | CO₂ Air quality

Minimum ventilation	Setting of batch curve for a lower limit of ventilation in relation to the air requirements of the animals (m ³ /h/animal). See also the section minimum ventilation [▶ 40].
----------------------------	---

☰ Menu button | 📄 Strategy | 🌀 Ventilation | Tunnel

Minimum air velocity in tunnel	At batch production. Setting of batch curve for the lowest air velocity acceptable in tunnel ventilation. At low air velocity, there is too much temperature difference from one end of the house to the other. This can be counteracted by setting a lower air velocity limit.
---------------------------------------	---

Chill factor	At batch production. Setting of batch curve for the cooling, which an animal of a given age and breed would experience at 1.0 m/s. See also the section Chill factor and chill effect [▶ 49].
---------------------	--

Maximum air velocity in tunnel	At batch production. Setting the lowest air velocity acceptable in tunnel ventilation. At high air velocity, there is a risk of excessive ventilation. Therefore, it is possible to set an upper limit for the air velocity. See also the section maximum ventilation [▶ 43].
---------------------------------------	--

4.4.3.1 Cycle timer at tunnel ventilation

When tunnel ventilating at low ventilation requirement (e.g. below 0.8 m/s), the distribution of air in the house can be ensured by means of a cycle timer. The controller will alternately switch the fans on and off. This will prevent temperature differences.

When the cycle timer function is active, the graphical status display is shown on the **Climate equipment** card.

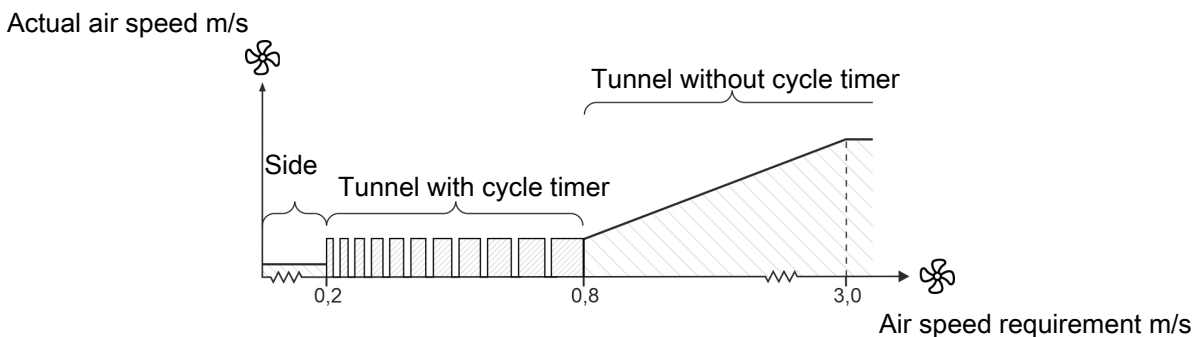

Figure 16: The ventilation sequence with cycle timer at tunnel ventilation

When a cycle timer is used at tunnel ventilation, the air velocity will cycle between 0.0 and 0.8 m/s. The setting for **Minimum air velocity** works as a start condition for tunnel, but now with the possibility to start at a lower setting, e.g., 0.2 m/s.

4.4.3.2 Chill factor and chill effect

The chill factor reflects the fact that the cooling effect of the air is dependent on the age and breed of the animals. The younger the birds, the colder they feel the temperature at a given air velocity.

The controller calculates the current cooling effect on the basis of speed inside the livestock the house and the current chill factor.

Air speed	1.5 m/s	1.5 m/s
Chill factor	3	8
Chill effect	4.5 °C	12 °C
30 °C feels like	25.5 °C	18 °C

Table 1: Chill factor and chill effect

The controller calculates which inside temperature is required in order to activate tunnel mode (only combi-tunnel).

- To make the change to tunnel at a lower inside temperature you must reduce the chill factor.
- To make the change to tunnel at a higher inside temperature you must increase the chill factor.

4.4.4 Combi-Tunnel ventilation

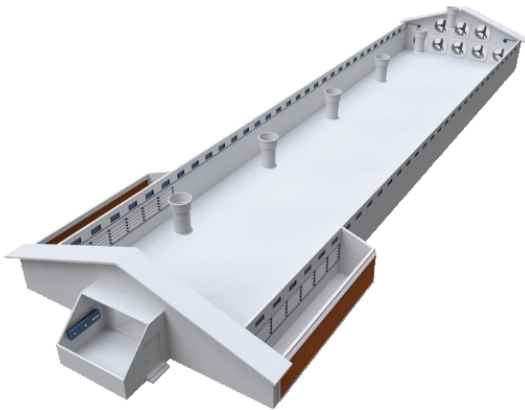

A combi-tunnel house provides the best possible productivity conditions in changing weather conditions, when the outside temperature changes from very cold to very hot.

The system adapts automatically the ventilation to the temperature outside, production type, and the age of the animals.

When the outside temperature is low, ventilation is conducted with side ventilation. The ventilation system keeps the temperature and humidity at an ideal level by removing the excess humidity and heat generated inside the house.

When the outside temperature is high, ventilation is done with tunnel ventilation. The ventilation system replaces the air in the house so that the animals are cooled using air velocity and cooling systems.



Operation | Climate equipment card

The current status values for combi-tunnel ventilation can be viewed via the Climate equipment card.

The graph on the card displays the current ventilation requirement (%) and how much of the ventilation is due to temperature and humidity and possibly CO₂, and what the air velocity (m/s) is at tunnel ventilation and what (m³/h/animals) is at side ventilation.

The climate equipment card provides furthermore access to following views:

- View of air inlet requirement.
- Graphic history curve.

The following sections describe the specific functions and setting options available for combi-tunnel. Furthermore, see the section Side ventilation and Tunnel ventilation for a description of regulation of side and tunnel ventilation.

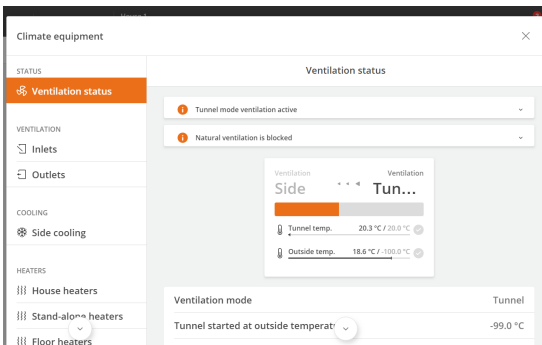

Operation | Climate equipment card | Ventilation status

The card shows the current values, which tell how the ventilation is running and when the regulation changes.

Force tunnel exit

It is possible to force the ventilation from the tunnel to side mode. This may be desirable in the case of mechanical failure or repair thereof.

Operation | Climate equipment card | Air outlet | Tunnel

Minimum air speed

Setting the lowest acceptable air velocity for tunnel ventilation.

At low air velocity, there is too much temperature difference from one end of the house to the other. Therefore, it is possible to set a lower limit for the air velocity.

Maximum air velocity

Setting the lowest air velocity acceptable in tunnel ventilation.

At high air velocity, there is a risk of excessive ventilation, for example in the case of small animals. Therefore, it is possible to set an upper limit for the air velocity.

Tunnel outside temperature limit

Setting a lower outside temperature limit for activation of tunnel ventilation.

Possible max. air velocity Reading the systems maximum air velocity.

Menu button | Strategy | Climate | Ventilation | Tunnel

Tunnel outside temperature limit	Setting a batch curve for a lower outside temperature limit enables tunnel ventilation activation.
Minimum air velocity in tunnel	Setting of batch curve for the lowest air velocity acceptable in tunnel ventilation. At low air velocity, there is too much temperature difference from one end of the house to the other. This can be counteracted by setting a lower air velocity limit.
Chill factor	The cooling, which an animal of a given age and breed would experience at 1.0 m/s. See also the section Chill factor and chill effect [► 49].
Maximum air velocity in tunnel	Setting the highest air velocity that can be accepted in tunnel mode. To avoid small animals being ventilated too vigorously, it is possible to set an upper limit for the air velocity in the house, Maximum air velocity .
Accepted experienced temperature drop	Setting how many degrees the perceived temperature must be below the temperature setpoint before changing from tunnel to side ventilation. See also the section Combi-tunnel ventilation: change between side and tunnel [► 51].
Last day that tunnel is blocked	Setting day number. The ventilation can only be switched to tunnel ventilation after this day, regardless of all other climate parameters. This function is intended for combi-tunnel houses in which you, out of consideration for small animals, wish to use tunnel ventilation only after a specific day number.

4.4.4.1 Combi-tunnel ventilation: change between side and tunnel

Change from side to tunnel

The controller changes to tunnel ventilation automatically when the following conditions have been fulfilled:

- Side ventilation is at maximum.
- Side cooling is at maximum.
- The inside temperature (tunnel temperature) is high enough to allow tunnel ventilation at minimum air speed.
- The limit for the outside temperature has been exceeded.

Change from tunnel to side

The controller changes to side ventilation automatically when the following conditions have been fulfilled:

- The outside temperature is more than 1 °C below the outside temperature present when the change to tunnel was made.
- The experienced temperature is 1 °C below the temperature setpoint and the air speed is on minimum.

4.4.5 Natural ventilation



Using natural ventilation, the air change takes place when air currents move between the adjustable air intake and the air outlet without any assistance of fans.

Natural ventilation can be used alone or in combination with other ventilation principles.

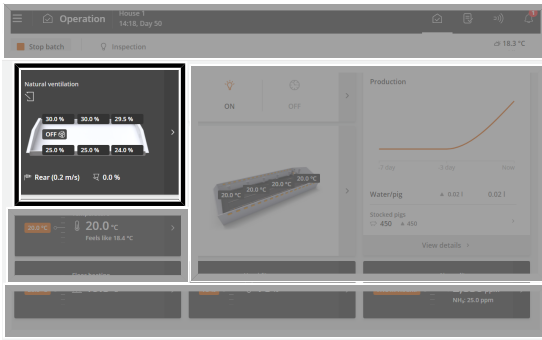

Operation | Climate equipment card

The current status values for natural ventilation can be viewed via the **Climate equipment** card.

The graph on the card displays the current ventilation requirement (%) and how much of the ventilation is due to temperature and humidity and possibly CO₂, and what the (m³/h/animals) is.

The climate equipment card provides furthermore access to following views:

- View of air inlet requirement.
- Graphic history curve.

Activation and deactivation of the function is controlled in relation to the outside temperature and can be set up in 2 different ways:

- **Relative values:** Start/stop are relative to outside temperature settings and therefore follow its course.
- **Absolute values:** Start/stop are fixed values that do not change in relation to the changing outside temperature.

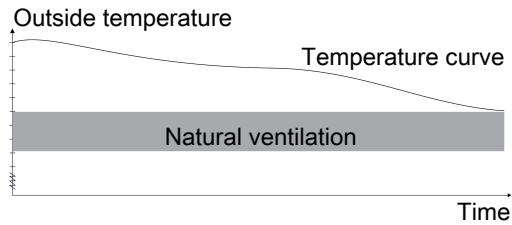
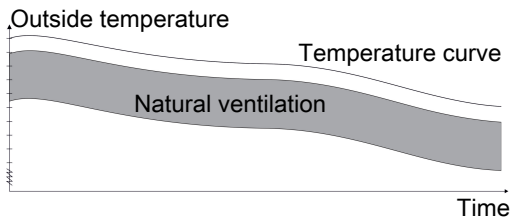

Setting options depend on the selected **Start/Stop conditions**. See also the Technical Manual.

4.4.5.1 Pure natural ventilation

With Natural ventilation, the air change takes place by air currents without a fan. Curtain openings on the sides of the livestock house are typically used as both air intake and air outlet. You can also use tunnel opening, open flap in exhaust unit or ridge opening as air outlet. The mechanical regulation is solely opening and closing of the inlets and outlets. Since no exhaustion takes place by means of fans, an energy saving is achieved and the noise level in the livestock house is reduced.

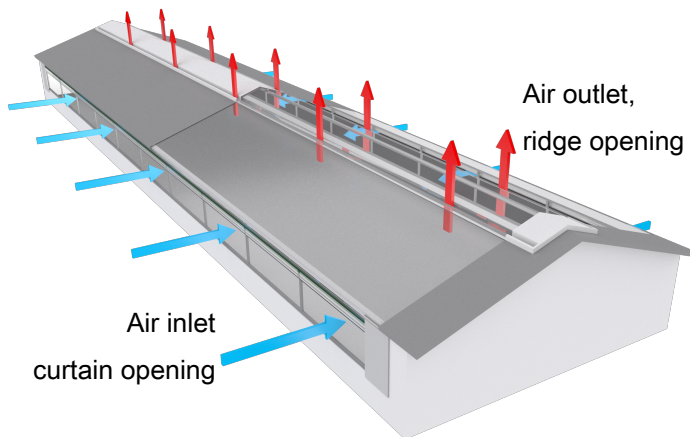
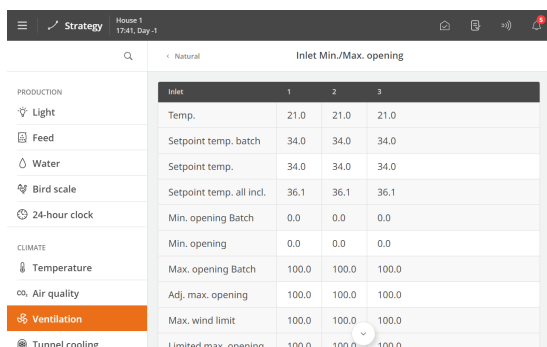

Figure 17: For example, on a house with pure natural ventilation with curtain openings on the sides of the house and ridge opening in the roof.



		Inlet Min./Max. opening		
		1	2	3
PRODUCTION	Inlet			
Light	Temp.	21.0	21.0	21.0
Feed	Setpoint temp. batch	34.0	34.0	34.0
Water	Setpoint temp.	34.0	34.0	34.0
Bird scale	Setpoint temp. all incl.	36.1	36.1	36.1
24-hour clock	Min. opening Batch	0.0	0.0	0.0
CLIMATE	Min. opening	0.0	0.0	0.0
Temperature	Max. opening Batch	100.0	100.0	100.0
Air quality	Adj. max. opening	100.0	100.0	100.0
Ventilation	Max. wind limit	100.0	100.0	100.0
Tunnel cooling	Limited max. opening	100.0	100.0	100.0

☰ Menu button | 📄 Strategy | Climate | Ventilation.

Natural ventilation can be adjusted via a batch curve.

Setting an opening percentage for minimum and maximum opening of the air inlet, respectively.

🏠 Operation | Climate equipment card | 📄 Inlets

Inlet cycle timer Setting the amount of time it takes both to open and close.

Cycle time inlets Menu for setting batch curve for cycle time.

Setting day numbers and the time that the air intake must be open. Closing time is calculated.

☰ Menu button | 📄 Strategy | Climate | 🌬️ Ventilation | Natural

Minimum ventilation (Natural) Menu for setting in per cent of air inlet and air outlet opening. Lower limit for how little opening you can have in Natural ventilation mode.

When **Minimum ventilation (Natural)** is set to a value exceeding zero, the air inlet and air outlet cannot close completely.

Minimum inlet position (Natural) Setting of minimum opening of air inlet.

See example below.

Maximum inlet position (Natural) Setting of maximum opening of air inlet.

See example below.

To ensure distribution of the fresh air during minimum ventilation **Cycle temp.** is used. When the inside temperature goes below the **Cycle temp.** for the respective inlet, this inlet will cycle between closed (**Min. Opening**) and open (**Inlet pos.**).

In the following example, inlet 5 will cycle between 16 % and 23 % when the inside temperature is below 21.5 °C.

Inlet	...	Min. opening Batch	Min. opening	...	Cycle temp.	Inlet pos.
1	...	15	10	...	19.5	20
2	...	15	10	...	19.5	20
3	...	15	12	...	19.5	22
4	...	15	15	...	19.5	25
5	...	15	16	...	21.5	23
6	...	15	19	...	21.5	20

☰ Menu button | 📄 Strategy | Climate | 🌬️ Ventilation | Natural

Cold protection offset Setting an offset to **Setpoint temp.**

When the inside temperature is too low, all natural inlets close and remain closed until the inside temperature is high enough again.

If the **Temperature setpoint** is 19 °C and the temperature drops below the cold protection offset, for example 5 °C (i.e. $19 - 5 = 14$ °C), all natural inlets close until the temperature again exceeds 14,5 °C (the 14 °C + 0.5 °C).

Cold protection starts below Display of the inside temperature at which the cold protection starts.

4.4.5.2 Natural ventilation combined with mechanical ventilation

Natural ventilation can be combined with other ventilation principles (LPV, Tunnel, and heat recovery) depending on how the ventilation system is constructed. When the required climate can no longer be sustained using Natural ventilation, the ventilation system switches to a different ventilation principle, for instance on the basis of too high or low outside temperature, too high CO₂ level in the livestock house or too high wind velocities.

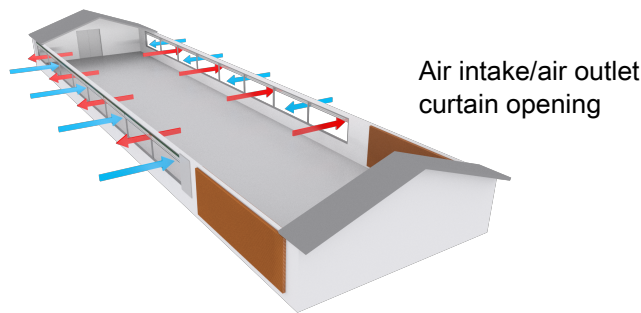

Figure 18: Example of livestock house with natural ventilation in combination with tunnel ventilation, Natural ventilation.

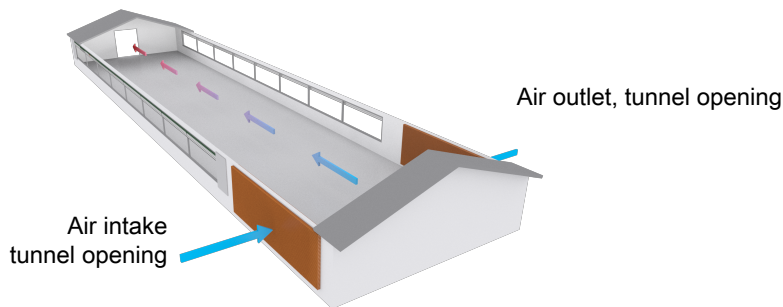

Figure 19: Example of livestock house with natural ventilation in combination with tunnel ventilation, Tunnel ventilation.

☰ Menu button | 📄 Strategy | 🌡️ Climate | 🌀 Ventilation | 🌿 Natural

Stop natural at outside temperature above	Setting of the high outside temperature where natural ventilation stops (Temperature setpoint+ High outside temperature offset). When controlled by Relative values , this is just at display.
Start natural at outside temperature below	Indication of the high outside temperature where Natural ventilation starts (Temperature setpoint + High outside temperature offset - High outside temperature hysteresis).
Start natural at outside temperature above	Indication of the low outside temperature where Natural ventilation starts (Temperature setpoint + Low outside temperature offset + 2 °C).
Stop natural at outside temperature below	Setting of the low outside temperature where Natural ventilation stops (Temperature setpoint + Low outside temperature offset). When controlled by Relative values , this is just a display.

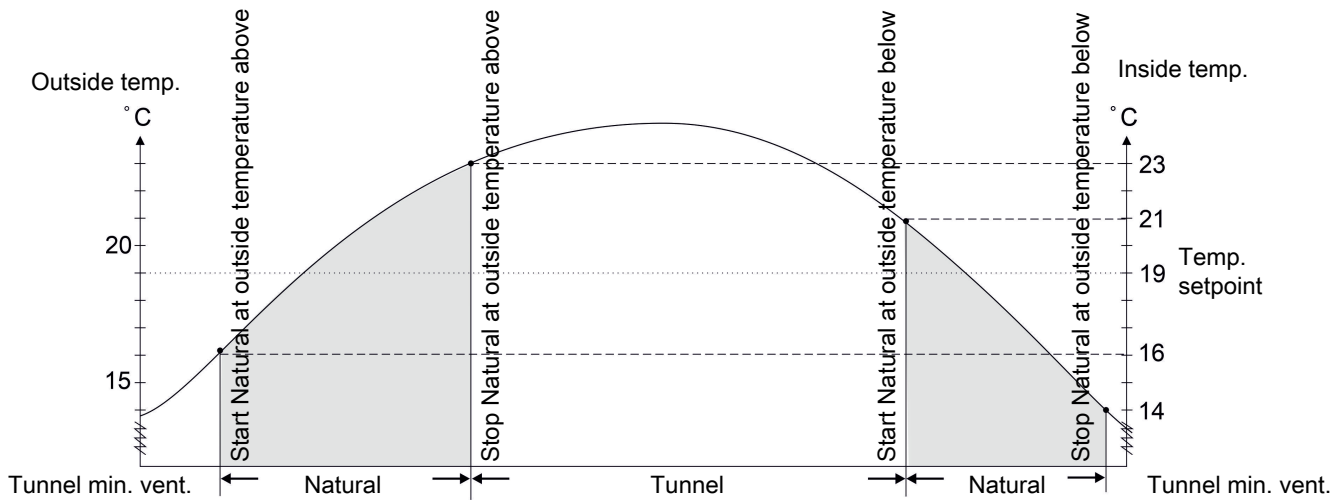

Figure 20: Natural ventilation is active dependent on the current outside temperature. Temperature setpoint is 19 °C.

Menu button | Strategy | Climate | Ventilation | Natural

High outside temperature offset Setting of a number of degrees added to the **Temperature setpoint** to establish an upper limit for the outside temperature. When outside temperature is above the limit, ventilation switches from Natural ventilation.

By changing this offset, you change the high temperature which starts and stops Natural ventilation. Make the setting higher to switch to Natural ventilation at a higher temperature.

High outside temperature hysteresis Setting of a number of degrees which postpones the switch to Natural ventilation at decreasing temperature. This makes regulation more stable so it does not constantly switch between the various ventilation principles.

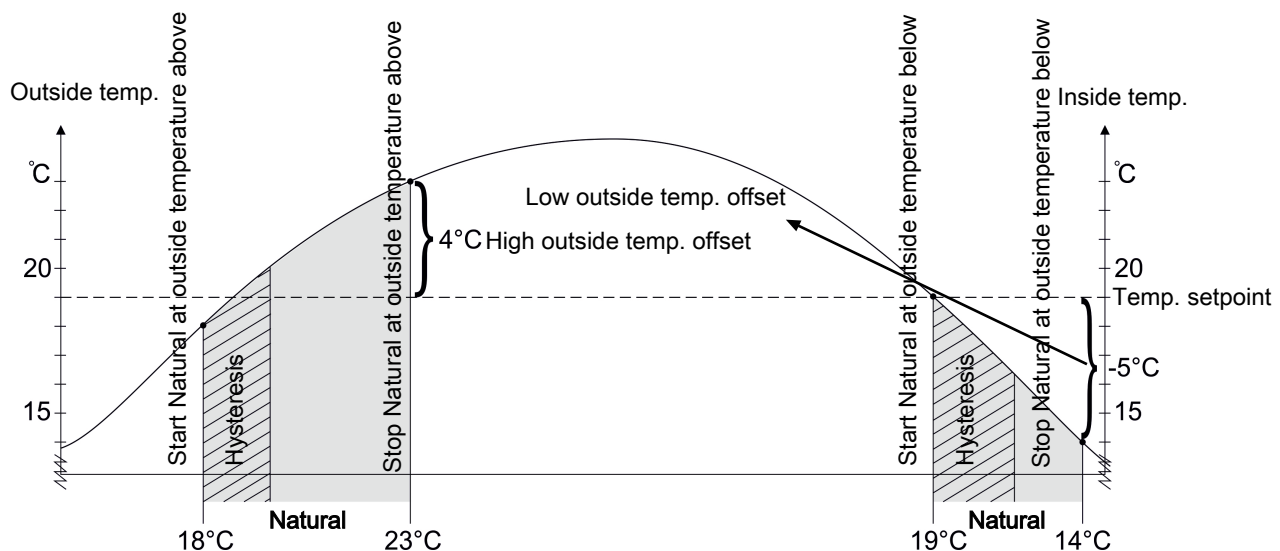

Figure 21: Natural ventilation is active dependent on the current outside temperature.

Operation | Climate equipment card | Outlets

Natural forced-to-start input	If a 3rd party sensor (e.g. daylight) is connected, Natural ventilation is automatically activated when receiving a signal from it. If the function is unavailable, the status is Inactive .
Natural forced-to-stop input	If a 3rd party sensor (e.g. rain) is connected, Natural ventilation is automatically deactivated when receiving a signal from it. If the function is unavailable, the status is Inactive .

4.4.5.3 Natural ventilation using CO2 sensor

Using a CO₂ sensor, you can monitor the current CO₂ level in the livestock house and use it as an indicator of the air quality.

 Menu button |  **Strategy** |  **Air quality** | **CO2 ventilation**

CO2	Setting of upper CO ₂ limit. When the limit is exceeded, the controller switches to mechanical ventilation including fans.
------------	--

4.4.5.4 Natural ventilation using weather station

When Natural ventilation is combined with a weather station, it is possible to take the current wind direction and wind speed into account when adjusting the ventilation.

 Menu button |  **Strategy** |  **Ventilation** | **Natural**

Inlet Min./Max. opening	Indication of the maximum allowable opening of the individual air inlets. The controller calculates the opening based on the current wind direction and speed. It reduces the opening of the air inlets in the windward side and increases the opening in the leeward side.
Wind comfort at 15 m/s	Setting of a number of degrees added to Temperature setpoint to minimize any draught problems in case of strong wind.
Wind comfort	Indication of the number of degrees that have currently been added to Temperature setpoint . The controller calculates a gradually increasing wind comfort. This is calculated based on the current wind speed (no addition at 0 m/s and maximum addition (4 °C) at 15 m/s). The addition is also corrected regarding wind direction (no addition in case of wind direction along the livestock house to maximum addition if wind direction varies from 60° to 90°).
Storm limit	Setting the upper wind speed limit. The controller switches to ventilation using fans at the preset wind speed (when other ventilation is available).
Maximum opening limit at high wind speeds	Setting an opening limitation for the air inlet at high wind speeds (opening in per cent).
Maximum opening limit start wind speed	Setting the wind speed which is to activate a limited opening of the air inlet (wind speed, 5 m/s). The air inlets can open 100% until the wind speed reaches this limit.
Maximum opening limit stop wind speed	Setting the wind speed where the full opening limitation of the air inlet has been reached (wind speed, 10 m/s). The air inlet can as a maximum open 30% when the wind speed reaches this limit.

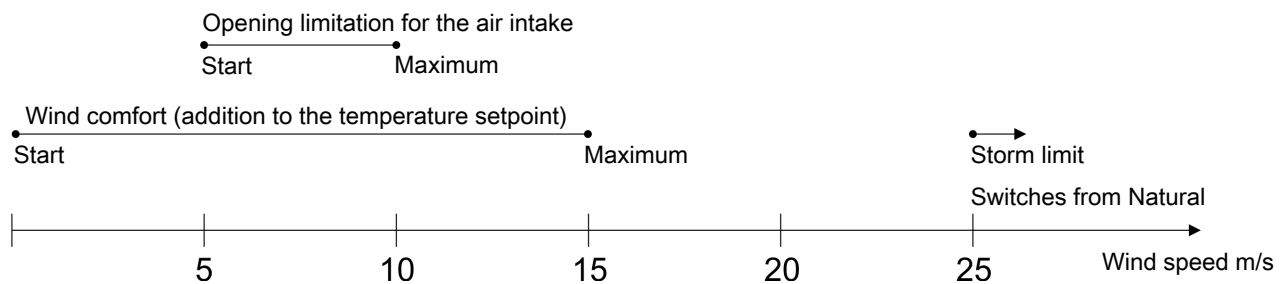

Figure 22: Natural ventilation at increasing wind speeds

To counteract draft at increasing wind speed the controller adds a number of degrees to the temperature setpoint. It also gradually reduces the opening of the air inlets.

The opening of the air inlets is also determined by the current wind direction. The opening is thus reduced on the side of the livestock house where the wind comes from.

See also the section Weather station [▶ 64] for a description of weather station.

4.4.6 Pressure

Based on measurements from a pressure sensor, the controller regulates the air intakes.

With negative pressure control the controller regulated the inlets so the required pressure is maintained in the house.

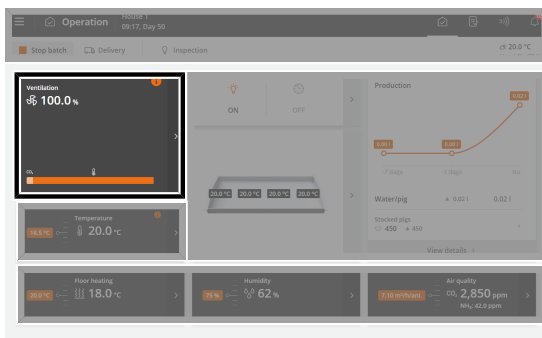

Operation. The current pressure level can be seen on the **Climate equipment** card.

Operation | Climate equipment card | Pressure

Pressure	Graphic display of the historical values in different time intervals from 24 hours to 2 months.
Pressure setpoint	Setting of the pressure level.
Pressure inlet requirement	Percentage indication of how much the flaps must be open to maintain Pressure setpoint .
Active in side mode	Connection and disconnection of pressure control at side ventilation.
Active in tunnel mode	Connection and disconnection of pressure control at tunnel ventilation.

4.4.6.1 Equal pressure ventilation

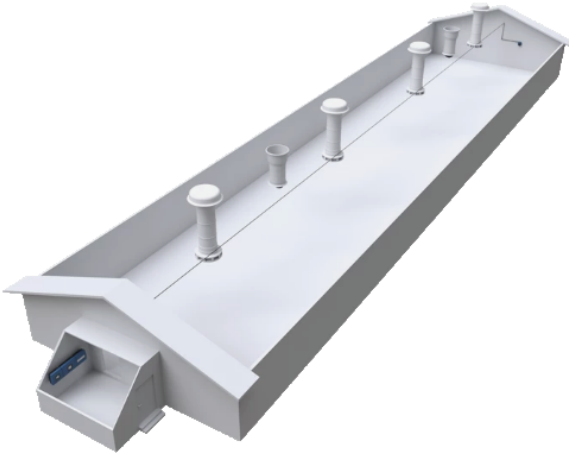

An equal-pressure ventilated house provides full air intake and outlet control.

The system is intended for temperate regions of the world and can be adapted to most house types.

In an equal pressure system, the fresh air is supplied through the roof inlets, and the air outlet is conducted through the exhaust units. Both are equipped with active fans to ensure neutral pressure.

4.4.7 Ventilation status

Stepless and MultiStep position

The air outlet in the house consists of partly one or several stepless exhaust units, partly groups of ON/OFF exhaust units. The stepless exhaust unit is variable, as the controller can adjust motor performance and flap opening of the fan, while the fans in the other exhaust units are either on or off.

The ventilation system connects the stepless exhaust unit first. When the ventilation requirement exceeds the capacity of the stepless exhaust unit, a group of the other exhaust units are connected and the stepless exhaust unit decreases its output simultaneously. This way, the controller ensures stepless transition from one ventilation level (MultiStep) to the next. If the ventilation requirement increases further, the stepless exhaust unit will perform up to its maximum until it reduces its output when the next group of ON/OFF exhaust units is connected.

All exhaust units in the house bear a sign showing if it is a stepless or an ON/OFF exhaust unit. The latter are numbered according to which MultiStep they belong. This way, it is possible to recognize the individual exhaust units and compare their actual output with the status that you can read in the Ventilation menu. This is particularly relevant in connection with fault finding.

Shutter position

The flap position is a percentage indication of how much the flaps of both air inlet and air outlet are open. If you are in doubt about the actual ventilation output, you can compare the reading of the Ventilation status in the ventilation menu with the output that you can actually observe in the house. The percentage indications are relevant particularly in connection with troubleshooting.

4.4.8 Parking of fans

With this function, fans can be taken temporarily out of service. It can, for example, be used in cold periods when some fans are closed for insulation purposes or if a fan is defective and awaiting repair.

We recommend that you only use parking for fans that are not actually in use. Otherwise, the ventilation control cannot automatically adapt to the changed ventilation capacity.



Operation | Climate equipment card | Outlets | Side outlets

MultiStep

Connection and disconnection of fans in each ON/OFF MultiStep.

If there has been ventilation at maximum level for 5 minutes, the controller will give a soft alarm to make you aware that you should activate the fans again.



Parking of fans must not be used as safety breaker in case of servicing the fan.



Be aware that if you park all tunnel fans in a Combi-Tunnel system, the controller can still switch to tunnel regulation of the ventilation - but without actually being able to use the tunnel fans.

This can be catastrophic for the animals.

4.4.9 Stir fan

A stir fan is typically used to improve air circulation inside the house and thus provide a more uniform temperature in the house. Depending on the type, location and connection method, however, it can be used for many different purposes.

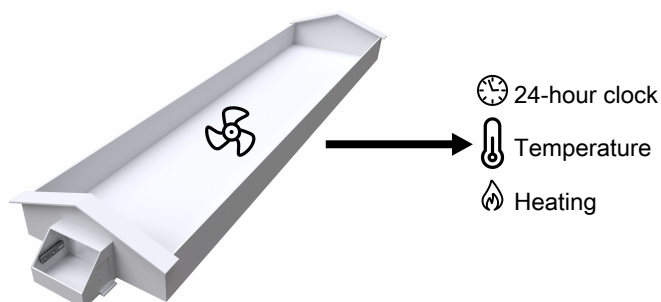

Operation | Climate equipment card | Stir fan

Status	ON/OFF fan: ON or OFF. Variable fan (0-10 V): fan speed in %.
Settings	Menu for setting of the individual fan. The content of the menu depends on the stir fan type. See the section below.

4.4.9.1 Regulation via 24-hour clock

The stir fan operates according to a set ON/OFF time and the time setting as to when it should start and stop.

Operation | Climate equipment card | Stir fan

Start time	Setting the time for the stir fan to be active.
Stop time	Setting the time for the stir fan not to be active.
ON-time	Setting the active period for the stir fan.
OFF-time	Setting the period during which the stir fan does not run while the function is active.
Start at ventilation	Setting of the ventilation level where the stir fan is to start.
Stop at ventilation	Setting of the ventilation level where the stir fan is to stop.
Activate override control	Selecting if it should be possible for the user to start and stop the stir fan manually.
Override relay status	Manual activation or deactivation of the stir fan - for example, to increase air movement shortly.

Start time: 14:00 hh:mm
 Stop time: 16:00 hh:mm
 ON time: 00:05:00
 hh:mm:ss
 OFF time: 00:05:00
 hh:mm:ss

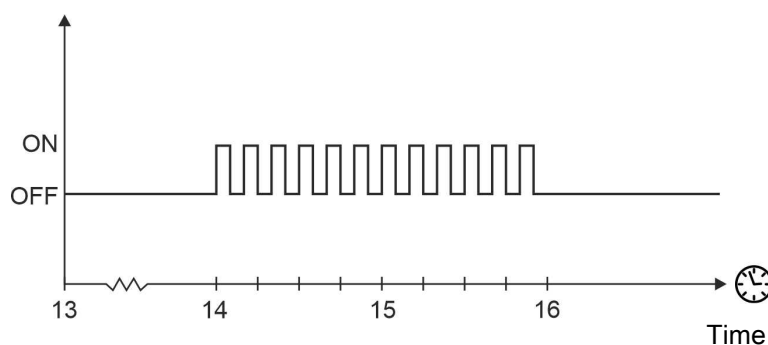



Figure 23: 24-hour clock control

4.4.9.2 Regulation via temperature

When a stir fan is operating in relation to the temperature in the house, set which sensor the controller should control according to and the temperature activating the stir fan.

Installation with relay (ON/OFF)

A relay-controlled stir fan can be regulated based on a measured temperature in the house (1 temperature) or based on a difference between two locations in the house (Differential temperature). When active, it will alternately run and be stopped for short periods.

 Operation Climate equipment card  Stir fan	
Mode	Select if the stir fan should be regulated by temperature or by a 24-hour clock.
Start at ventilation/ Stop at ventilation	Setting the active ventilation area for the stir fan to be active. When the ventilation requirement is above and below this level, the stir fan is not active. Not used in livestock houses with only natural ventilation.
Control	Select control of the stir fan. One temperature: The control takes place according to an offset to the inside temperature. Difference temperature: The control takes place according to the temperature difference between the selected sensors.
Temperature sensor selection	Selecting which temperature sensors should be used for controlling the stir fan.
ON-time	Setting the active period for the stir fan.
OFF-time	Setting the period during which the stir fan does not run while the function is active.
Activate override control	Selecting if it should be possible for the user to start and stop the stir fan manually.
Override relay status	Manual activation or deactivation of the stir fan - for example, to increase air movement shortly. Remember to deactivate the function again.
1 temperature sensor	
Start temperature offset	Setting an offset to Temperature setpoint. The stir fan is activated when the inside temperature exceeds Temperature setpoint + Start temperature offset . At high temperatures, a stir fan can be used to create the experience of cooling via air speed.
Stop temperature natural	Setting of the temperature where the stir fan stops.
Stop temperature side / tunnel	In livestock houses that also have side/tunnel ventilation. Display of the temperature where the stir fan stops at side and tunnel ventilation.
Differential temperature	
Temperature difference activation	Setting the temperature difference between the 2 sensors. The stir fan is activated when the temperature difference exceeds the setting. In case of temperature differences in the house, a stir fan can be used to compensate for temperature differences between colder and warmer areas.

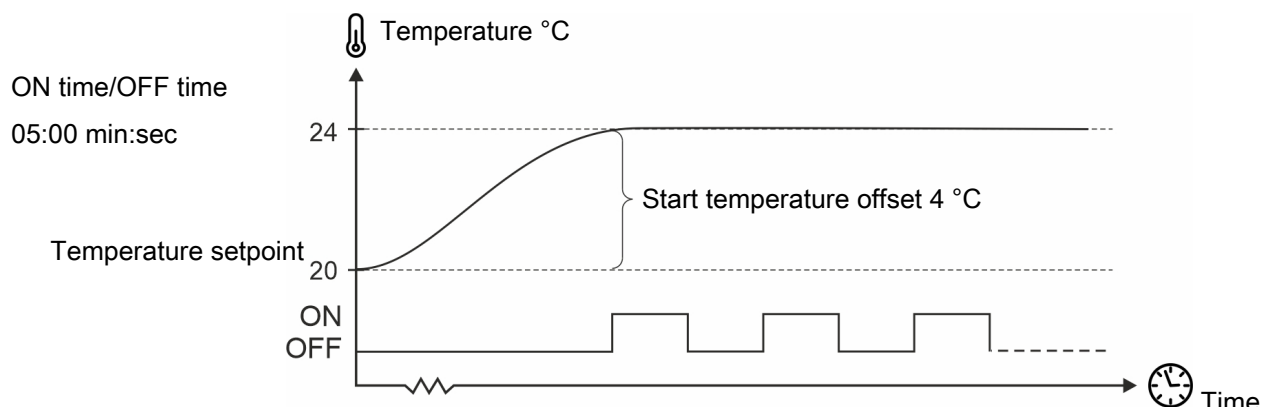

Figure 24: Relay-controlled stir fan (ON/OFF) controlled by temperature

Installation with 0-10V (variable)

A 0-10 V controlled stir fan can be regulated based on a measured temperature in the house. It varies in speed relative to the temperature.

Operation | Climate equipment card | Stir fan

Start at ventilation/ Stop at ventilation	Setting the active ventilation area for the stir fan to be active. When the ventilation requirement is above and below this level, the stir fan is not active. Not used in livestock houses with only natural ventilation.
Minimum speed	Setting the speed at which the stir fan starts.
Maximum speed	Setting the maximum speed at which the stir fan is running.
Temperature sensor selection	Selecting which temperature sensor to use for the control.
Start temperature offset	At high temperatures, a stir fan can be used to create the experience of cooling via air speed. Setting an offset to Temperature setpoint. The offset can be set as a positive or negative value. Positive value: The stir fan starts at an excess temperature to Temperature setpoint . E.g. 15 °C +5 °C = 20 °C. Negative value: The stir fan starts at a temperature below Temperature setpoint . E.g. 15 °C -5 °C = 10 °C.
Stop temperature natural	Setting the temperature that stops the stir fan at natural ventilation.
Stop temperature side / tunnel	In livestock houses that also have side/tunnel ventilation. Display of the temperature where the stir fan stops at side and tunnel ventilation.
Variable temperature range	Setting an inside temperature range where the stir fan will run between minimum and maximum speed.
Activate override control	Manual activation of the stir fan. It will run at the speed set in Override speed . Remember to deactivate the function again.
Override speed	Setting the speed that the stir fan must run at when in manual override.

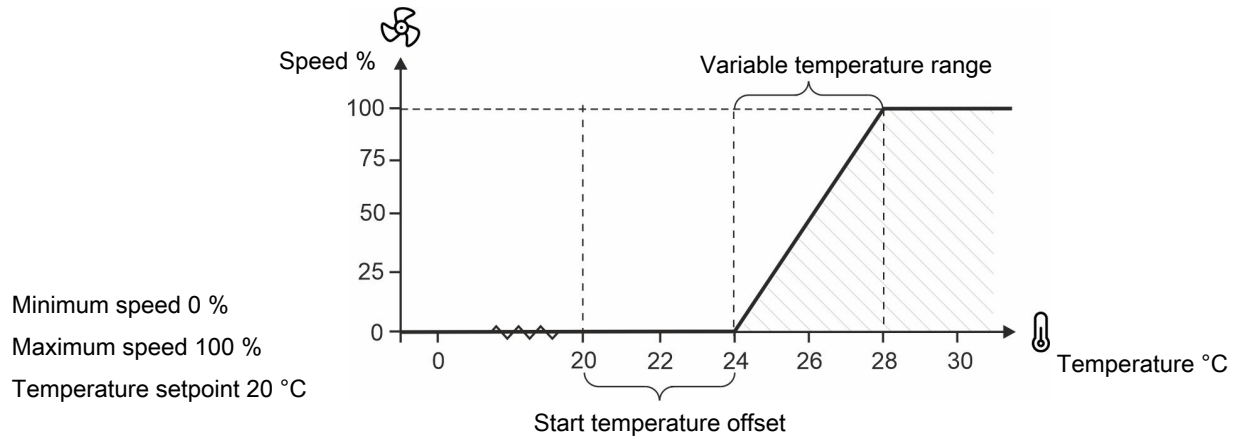

Figure 25: 0-10 V controlled stir fan with a positive Start temperature offset.

Installation of 0-10V and reverse relay (variable)

An 0-10V-controlled stir fan with reverse relay works as described above but can also reverse the rotation of the stir fan.

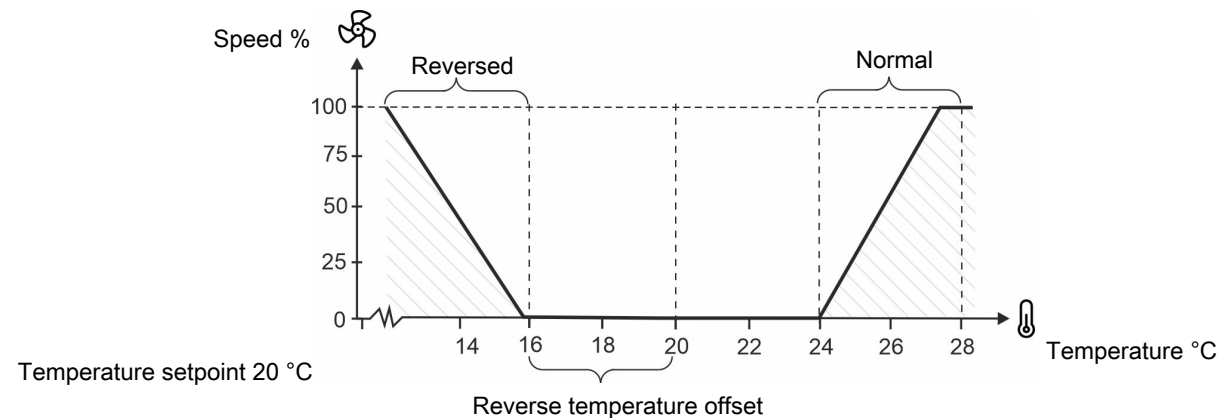

Figure 26: 0-10 V-controlled stir fan with reverse relay

Operation | Climate equipment card | Stir fan

Stir fan 1 direction	Display of direction of rotation (Normal/Reverse) for the stir fan (at reverse relay).
Reverse temperature offset	Setting an offset to Temperature setpoint. When the inside temperature deviates from the temperature setpoint, the stir fan is activated. The offset can be set to a negative value so the air direction is reversed at falling inside temperature.
Override direction	Choice of revolution direction of the fan (Normal/Reverse).

4.4.9.3 Regulation via heat source

When the stir fan is to operate in connection with heat sources, you must opt for a way to control and set the start and stop time of the fan

Control:

With heater: The stir fan runs while the heat source supplies heat, but starts and stops with a set time delay (**Start delay/ Stop delay**).

After heater: The stir fan runs after the heat source has supplied heat. It starts with a time delay (**Start delay**) and runs for a set period of time (**ON time**).

This function is active only when heating is required.

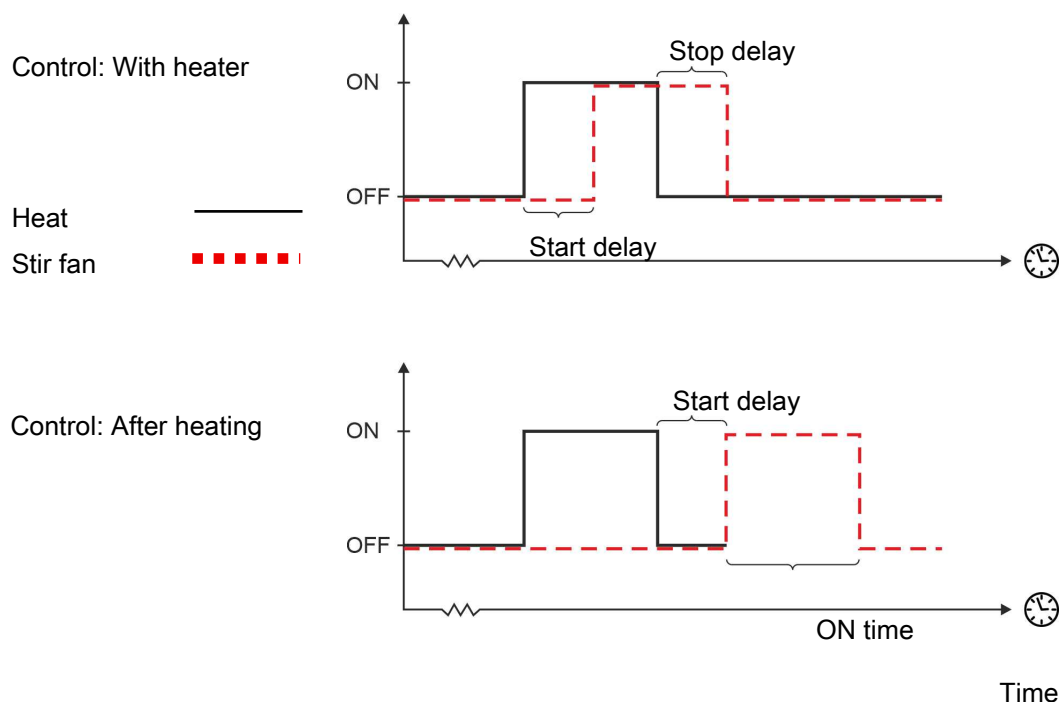

Figure 27: Heat source regulation

Operation | Climate equipment card | Stir fan

Control by heater no.	Selection of the heat source to be activated together with the stir fan.
Start at ventilation	Setting of the ventilation level where the stir fan is to start.
Stop at ventilation	Setting of the ventilation level where the stir fan is to stop.
Control	Selecting if the stir fan is to start together with heating or after heating.
Start delay	Setting the delay time for the stir fan to start.
Stop delay	At With heater . Setting the delay time for the stir fan to stop.
ON time	At After heat . Setting how long the stir fan should run.
Activate override control	Selecting if it should be possible for the user to start and stop the stir fan manually.
Override relay status	Manual activation or deactivation of the stir fan - for example, to increase air movement shortly.

4.4.10 Weather station

The weather station is used to record wind direction and speed.





Operation | Climate equipment card |



FreeRange | Weather station

History	A total overview of the development can be seen from the history curves, which can show the values at different time intervals from 24 hours to 2 months.
Average wind direction – absolute	Display of the average wind direction in relation to the corners of the world.
Average wind direction - relative	Display of the average wind direction in relation to the house (front/rear)
Average wind direction relative to barn	Display of the average wind direction in degrees in relation to the house. The direction is displayed in degrees in relation to the house.
Wind direction	Display of the current wind direction.
Average wind speed	Display of the average wind speed.
Wind speed	Display of current wind speed.

The average values are only shown when selected in the menu   | **Installation | Manual installation | Climate | Sensors | Weather station.**

4.5 Delivery

Delivery is a function that is designed to adapt the ventilation in connection with the animals having to leave the house. The ventilation status will change to **Delivery** and adapt its settings. When it changes back, the ventilation returns to half the ventilation requirement requested before the function started.

The daily user sets a period during which the function can be activated.

When the external carrier comes to the livestock house, he activates **Delivery** manually or by pressing the controller's display or with an external key.



Operation | Delivery

Delivery	Connection and disconnection of the function. (with display operation)
Delivery ready	Setting the date and time that the user can activate the function.
Delivery start	Displaying the time when catching was activated. Only visible when the function is active.
Delivery stop	Displaying the time when the function is to stop (using the Auto stop Delivery after). If the catching lasts longer than expected, the stop time can however be changed. Only visible when the function is active.
Allow delivery start period	Setting the time period when the user can activate the function. (only push button and key)
Auto stop delivery after	Setting the maximum period that Delivery can be active.
Air inlet	Setting how much the air inlets must be open in percent during delivery.
Roof inlet	Setting roof inlet, flap, fan and stir fan in percent during delivery.
Stepless	Setting how much the air inlets must be open in percent during delivery.
MultiSteps	Selecting which MultiStep should be active during Delivery . For example, you can control the desired airflow direction, by only activating the MultiSteps at one end of the house.

4.6 Cooling

4.6.1 Cooling potential

The cooling potential is a way to describe how much the air temperature can be lowered by adding water-based cooling.

The cooling potential for water-based cooling thus depends on the humidity and the outside temperature.

In general there is a higher cooling potential in hot areas than in cold areas. Furthermore, there will usually be a very high cooling potential in areas with very low humidity.

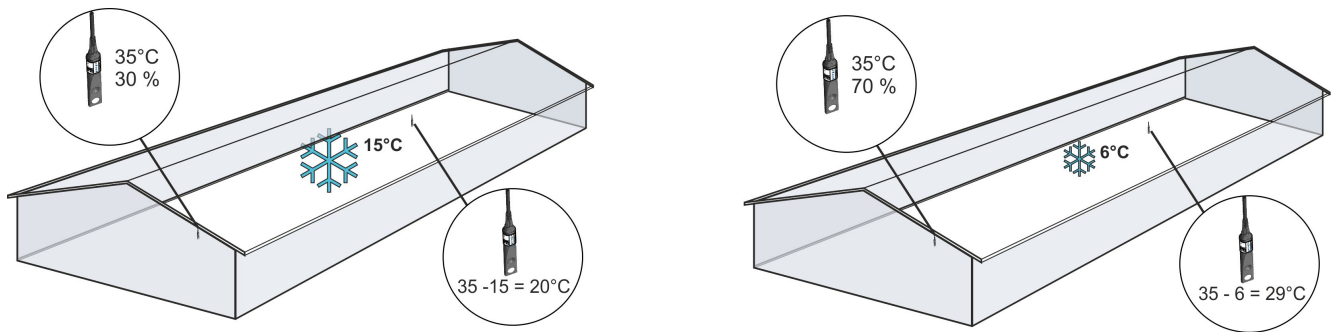

Figure 28: The lower the outside humidity, the higher the cooling potential.

A rule of thumb states that for each 5 % increase in air humidity, the temperature drops by 1 °C.

4.6.2 Side cooling

Cooling is used in houses where ventilation alone cannot reduce the inside temperature sufficiently.

Cooling has the advantage over ventilation that it can bring the inside temperature down below the outside temperature. On the other hand, cooling will also increase the air humidity in the house.

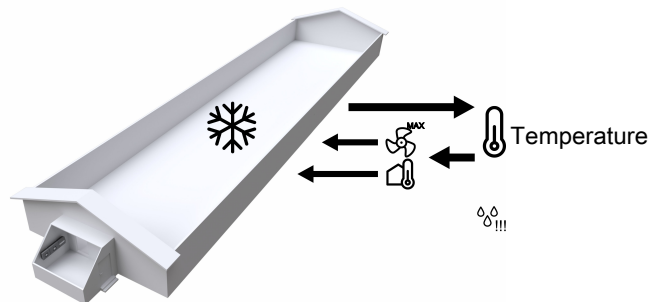

The combination of a high inside temperature and high air humidity can be life-threatening to the animals. As cooling makes the house humidity increase, the controller automatically disconnects cooling when the house humidity exceeds **Humidity to stop side cooling** (normally 75-85%, factory setting: 85 %).



Operation. The most important cooling values can be viewed and adjusted via the **Climate equipment** card.

When cooling is active, this is shown in the upper right corner of the card.

The following sections describe the functions and setting options available for Side cooling.



Operation | Climate equipment card | ❄️ Side cooling

Side cooling	Graphic display of the historical values in different time intervals from 24 hours to 2 months.
Requirement incl. humidification	Only when humidification is connected to the relay for side cooling system. This is particularly useful in hot and dry areas where side cooling will run alternately to the humidification, respectively to cool and increase humidity. Display of how big a percentage of the side cooling system's capacity that is currently active.
Start cooling offset	The number of degrees by which the temperature is to exceed Temp. setpoint incl. additions before cooling starts. The controller gradually increases cooling.
Absolute start temperature	Display of the measured inside temperature at which side cooling starts.
FreeRange start cooling	Setting an offset to the batch curve FreeRange cooling start temperature. The value is reset at batch start.

Humidity to stop side cooling

The air humidity percentage that makes the controller stop the cooling function. Furthermore, a humidity limit can be set for the tunnel cooling.

Cooling is gradually removed 10% before the humidity limit.

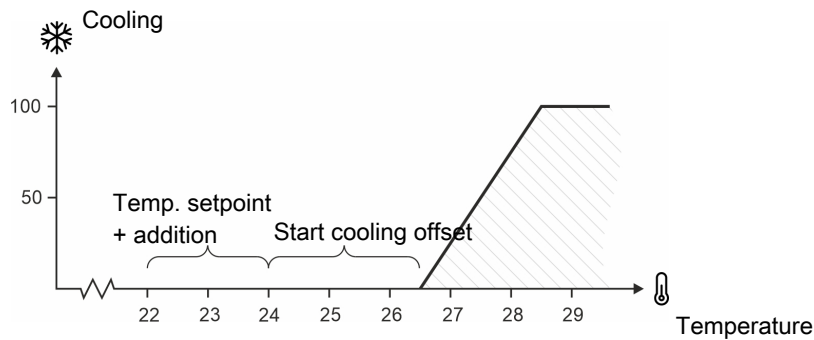

Figure 29: Cooling

A prerequisite for cooling to be able to start is that ventilation is set to **Maximum ventilation** or that the outside temperature is above **Temperature setpoint**.

4.6.2.1 Start cooling

As a standard the climate controller will adjust for an increasing inside temperature by increasing the ventilation. The cooling does not start until the climate controller is unable to maintain the temperature by ventilating.

4.6.2.1.1 Side cooling start based on ventilation level

The function **Cooling before max. ventilation** makes it possible to start cooling at a lower ventilation level.

An early start of the cooling is particularly relevant in hot and dry areas. When you increase the ventilation level, you get hot outside air into the livestock house. A smaller air volume needs cooling if you activate the cooling at an earlier stage. It reduces both power and water consumption.

The function is only available when an outside humidity sensor is installed.

With this setting the climate controller will continuously calculate the ventilation level at which the side cooling must start.

The calculations are based on the current outside humidity and outside temperature and indicate a so-called cooling potential. See also the section Cooling potential [▶ 66].

☰ Menu button | 📄 Strategy | ❄️ Cooling

Cooling before max. ventilation	Activation and de-activation of the function. From the factory the function is not activated.
Cooling priority	Selecting how early in the ventilation sequence, cooling should start (Minimum/Medium/Maximum). See section Cooling priority [▶ 69].
Required ventilation to start cooling:	Displays the calculated ventilation level at which cooling will start (in percent of Maximum ventilation). Maximum ventilation is either determined as batch curve or set in the menu Technical Service Settings Climate Air output .

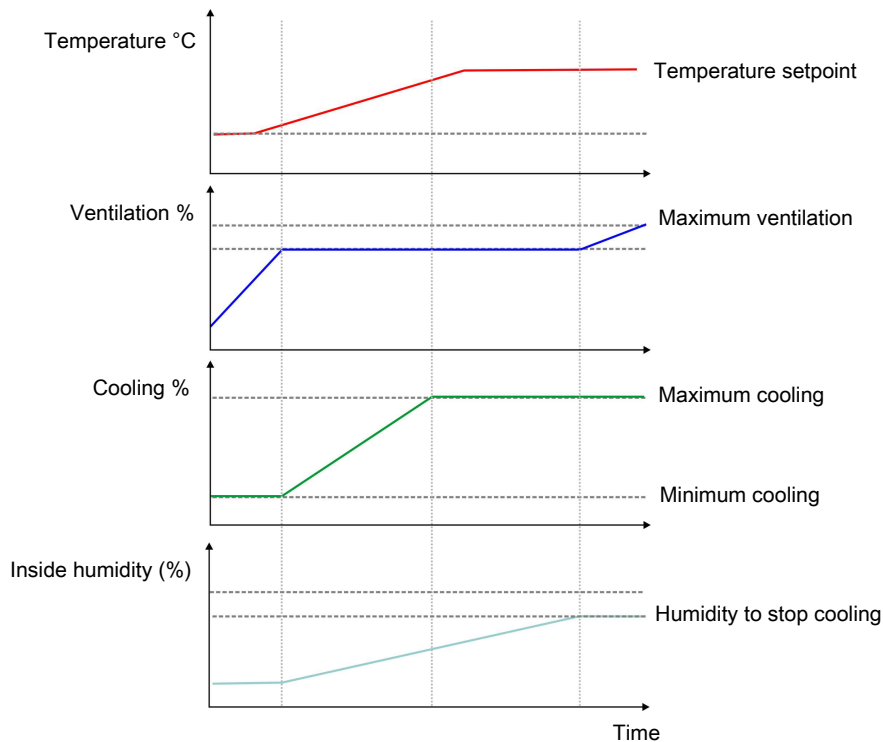

Figure 30: To maintain the required inside temperature, cooling starts before the ventilation level has reached Maximum ventilation. When cooling can no longer maintain the temperature, the ventilation is increased again.

4.6.2.1.1.1 Cooling priority

It is possible to select the priority of cooling starting early: minimum, medium and maximum.

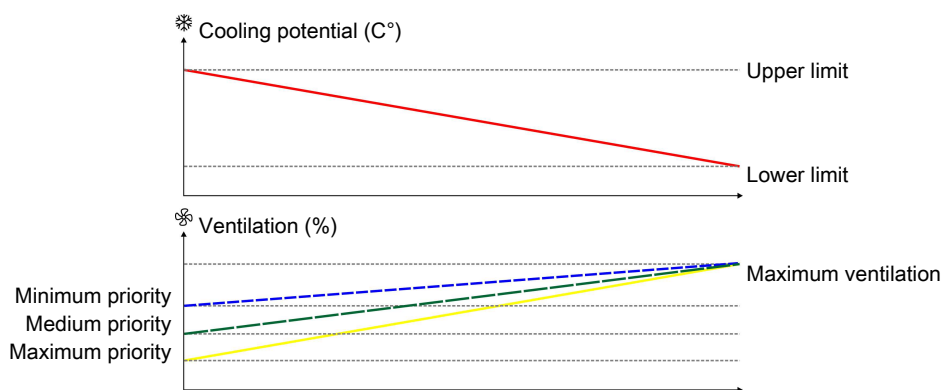

Figure 31: The higher the cooling potential, the higher priority of early cooling start.

Minimum:

Used in areas where the temperature is primarily maintained by means of ventilation and where the cooling potential is low.

At a cooling potential of 15 °C, cooling will, for example, start at 80 % of the maximum ventilation.

Medium:

Factory setting. Usually the factory setting should not be changed. It may be necessary to change the cooling priority, if the adjustment takes place too slowly or too quickly.

At a cooling potential of 15 °C, cooling will, for example, start at 60 % of the maximum ventilation.

Maximum:

Used in areas where the temperature is primarily maintained by means of cooling and where the cooling potential is high.

At a cooling potential of 15 °C, cooling will, for example, start at 40 % of the maximum ventilation.

4.6.2.2 Nozzle cleaning

To clean the nozzles, the controller can activate side cooling independently of the house's cooling requirement.

 Menu button |  **Strategy** |  **Cooling** | **Nozzle cleaning**

Nozzle cleaning active	Connection and disconnection of nozzle cleaning.
Nozzle cleaning interval	Setting the time between when side cooling was active to when the nozzle cleaning function starts.
Nozzle cleaning time	Setting of the time when nozzle cleaning function shall run.

4.6.3 Spraying and behavior control

Spraying can help prevent wallowing by ensuring that the animals can regulate the temperature through water evaporation from the body surface.

The spraying can be set run depending on the inside and outside temperature and/or time.

The spraying system can also be used for behavior control. The behavior control runs according to the same settings as the spraying that cannot start simultaneously.

Operation | Climate equipment card | Spraying

Activate spraying	Connection and disconnection of the spraying.
Spraying requirement	View of current spraying requirement.
Minimum spraying	Setting of a percentage of the spraying system's capacity that the system shall run at as a minimum. Most often, Minimum spraying will be set to 0%.

Menu button | Strategy | Spraying

Outside low stop temperature	Setting of a lower temperature limit for when spraying can run.
Start time	Setting of a time for the start of spraying.
Stop time	Setting of a time for spraying to stop.
Forced start at outside temperature above	Setting of an outside temperature that will start the spraying even in the stop period.
Spraying 1-100%	Matrix for setting up the spraying cycle (Temp./ON/Cycle).
Installation of behavior control	Activation of the function Behavior control. See the section Behavior control [► 73].



Spraying can ensure the animals' requirement for natural temperature regulation with water evaporation from the surface of the body.

4.6.3.1 Spray sequence

In accordance with inside temperature

Spraying starts when the inside temperature exceeds the temperature limit setpoint. The spraying is increased automatically the higher the temperature rises.

Temperature setpoint: 22 °C
Requirement 1%: 0.5 °C
Requirement 100%: 3 °C

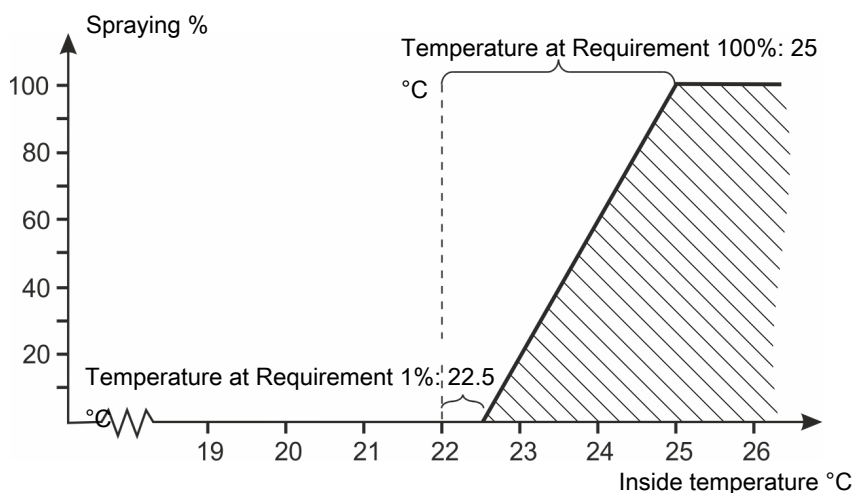

Figure 32: Spraying in accordance with inside temperature

You must set the Spraying 1-100% with the number of degrees that the temperature must rise above the Temperature setpoint for spraying to start.

If you want spraying to be independent of the inside temperature, you can disregard the function by making both setpoints for Temperature at x% to -1°C for example.

4.6.3.2 Limitation of spraying

The other settings in the spraying menu can act as start conditions that must be fulfilled for spraying to be able to start.

Spraying can only start when the outside temperature is above the temperature for **Stop at outside temperature below**, and only within the set period.

However, an upper outside temperature limit can be set which will also activate spraying outside the set period, if the inside temperature is sufficiently high.

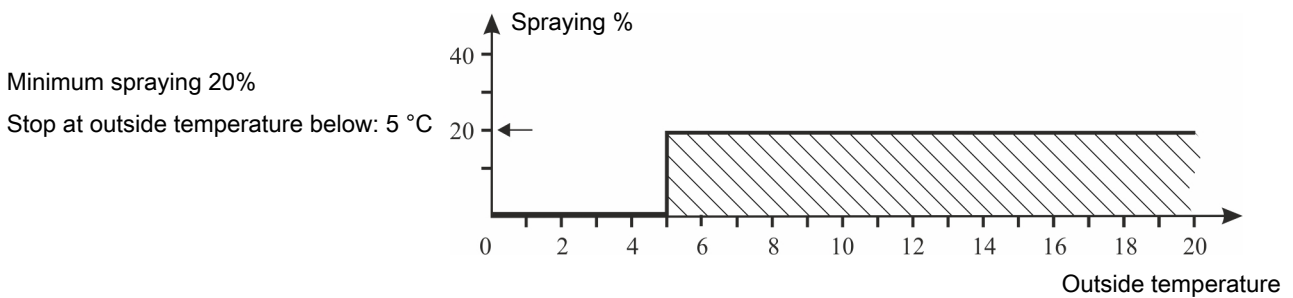

Figure 33: Spraying in accordance with outside temperature

If you want spraying to be independent of the outside temperature, you can disregard the function by setting Stop at outside temperature below down to -10°C for example.

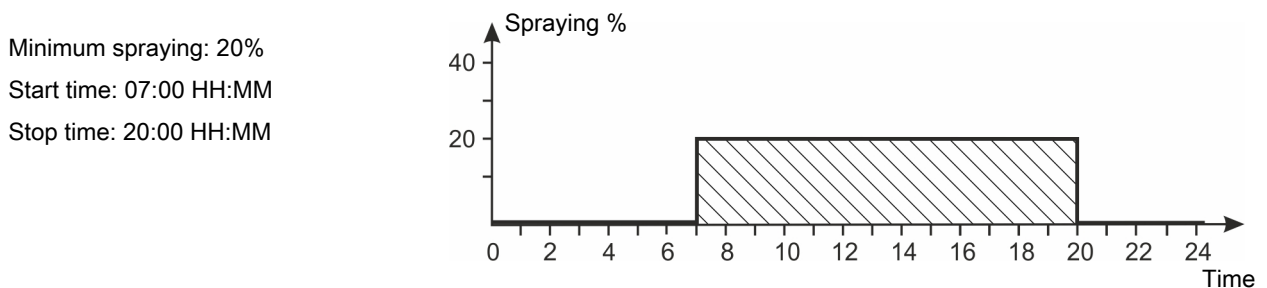

Figure 34: Spraying in accordance with time

If you want the spraying function to be active all the time, you can disregard the function by setting the Start time and Stop time to the same time.

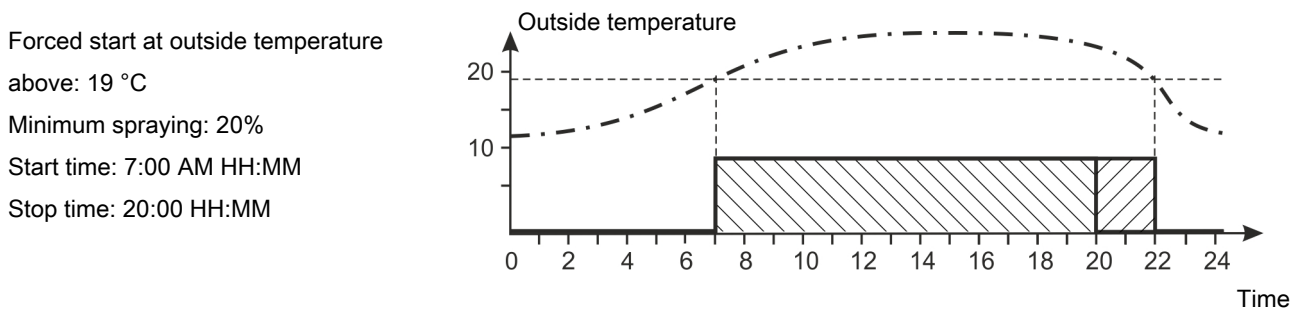

Figure 35: Spraying in accordance with time and outside temperature

Spraying continues after the stop time when the outside temperature is above the limit.

Spraying according to outside temperature does not start unless the inside temperature limits have been exceeded.

4.6.4 Behavior control

The spraying system can be used for behavior control by spraying an area of the pen to make the animals choose to lay in another area of the pen.

Spraying typically runs in a cycle with short sprays and long pauses.

Behavior control cannot be started if spraying is disabled.

 **Operation** |  **Spraying** button

Duration	Setting for how long the behavior control should run.
ON time	Setting of how long water shall be sprayed on the animals each time.
Cycle time	Setting of the time between water being sprayed on the animals.

 **Operation** |  **Strategy** |  **Spraying**

Behavior control installed	Connection and disconnection of behavior control.
Spraying deactivated	View of the current status for spraying.

4.6.5 Tunnel cooling

Cooling is used in houses where ventilation alone cannot reduce the inside temperature sufficiently. Cooling has the advantage over ventilation in that it can bring the inside temperature down below the outside temperature. On the other hand, cooling will also increase the air humidity in the house.

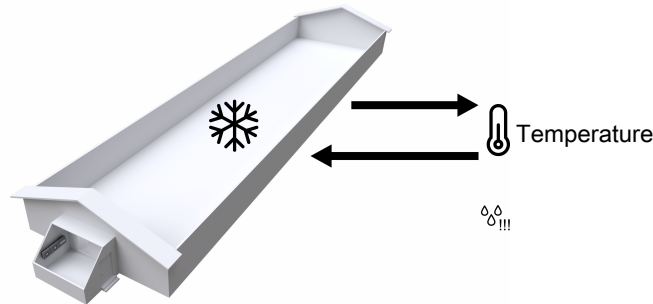

The combination of a high inside temperature and high air humidity can be life-threatening to the animals. As cooling makes the house humidity increase, the controller automatically disconnects cooling when the house humidity exceeds **Humidity to stop tunnel cooling** (normally 75-85%, factory setting: 85 %).

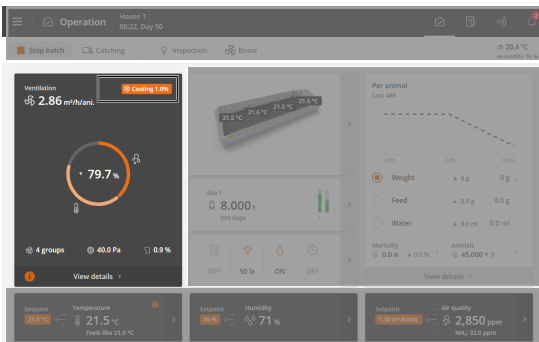

Operation. The most important cooling values can be viewed and adjusted via the **Climate equipment** card.

When cooling is active, this is shown in the upper right corner of the card.

In order to ensure that the cooling system does not run under inappropriate conditions (not desirable due to the well-being of the animals), the controller will stop the cooling. Thus cooling can be blocked by air speed, temperature, tunnel cooling temperature, humidity and humidity sensor error.

The following sections describe the functions and setting options available for tunnel cooling.

4.6.5.1 Tunnel cooling settings

Tunnel cooling can be set to start based on 3 different factors:

- Fixed air speed
- Adjusted air speed
- Temperature



Menu button |



Strategy |



Tunnel cooling

Calculated cooling start

Reading of the temperature that the tunnel cooling is controlled by when a dedicated tunnel cooling sensor is used.

Start based on

Selecting which factor is to activate tunnel cooling (**Fixed air speed / Adaptive air speed / Temperature**).

See the sections Tunnel cooling start based on a fixed air speed [▶ 75], Tunnel cooling start based on an adapted air speed [▶ 75], and Tunnel cooling start based on inside temperature [▶ 76].

4.6.5.2 Start cooling

As a standard the climate controller will adjust for an increasing inside temperature by increasing the ventilation. The cooling does not start until the climate controller is unable to maintain the temperature by ventilating.

4.6.5.2.1 Tunnel cooling start based on a fixed air speed

Operation | Climate equipment card | Tunnel cooling

Start air speed	Setting the air speed that starts the tunnel cooling.
Humidity to stop tunnel cooling	The percentage of air humidity that makes the controller stop the tunnel cooling. The tunnel cooling restarts at 3 % below the humidity limit. Furthermore, you can set a humidity limit for the side cooling.

Menu button | Strategy | Tunnel cooling

Calculated cooling start	Calculation of the inside temperature starting the tunnel cooling, when the launch is based on air speed.
---------------------------------	---

4.6.5.2.2 Tunnel cooling start based on an adapted air speed

The function makes it possible to start the cooling at a low ventilation level.

An early start of the cooling is particularly relevant in hot and dry areas. When you increase the ventilation level, you get hot outside air into the livestock house. A smaller air volume needs cooling if you activate the cooling at an earlier stage. It reduces both power and water consumption.

The function is only available when an outside humidity sensor is installed.

With this setting, the controller will continuously calculate at which air speed the tunnel cooling should start.

The calculations are based on the current outside humidity and outside temperature and indicate a so-called cooling potential. See also the section Cooling potential [▶ 66].

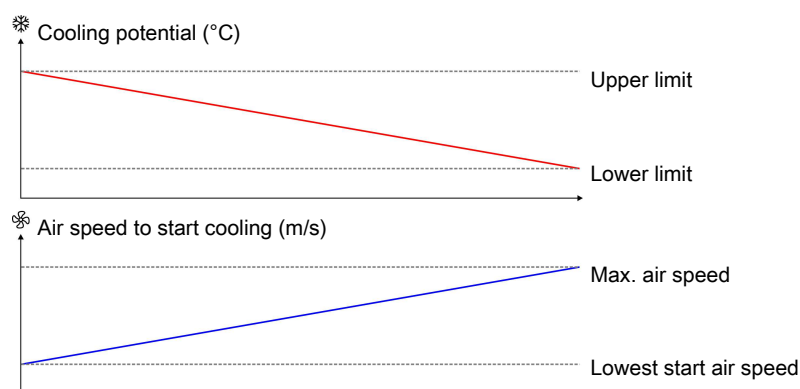

Figure 36: In areas with low outside humidity and a large cooling potential, cooling can start at a lower air speed. Whereas in areas with low cooling potential, cooling will start as late as possible, meaning that it starts at maximum air speed.

Operation | Climate equipment card | Tunnel cooling

Humidity to stop tunnel cooling	Setting the percentage of air humidity that makes the controller stop the tunnel cooling. The tunnel cooling gradually stops 10 % before reaching the humidity limit and restarts 3% below the humidity limit. Furthermore, you can set a humidity limit for the side cooling.
--	--

Menu button | Strategy | Tunnel cooling

Lowest tunnel cooling start speed	Setting the batch curve for the air speed required before the tunnel cooling can start. The purpose is to ensure that there is a certain air speed in the livestock house when the cooling is active.
--	---

Calculated cooling start	Calculation of the inside temperature starting the tunnel cooling, when the launch is based on air speed.
Lowest cooling start speed	Adjustment of the air speed required (set as batch curve) before the tunnel cooling can start.
Current cooling start speed	View of the air speed at which the tunnel cooling may start at this moment. The value is calculated based on the current cooling potential. Also, see the figure above.

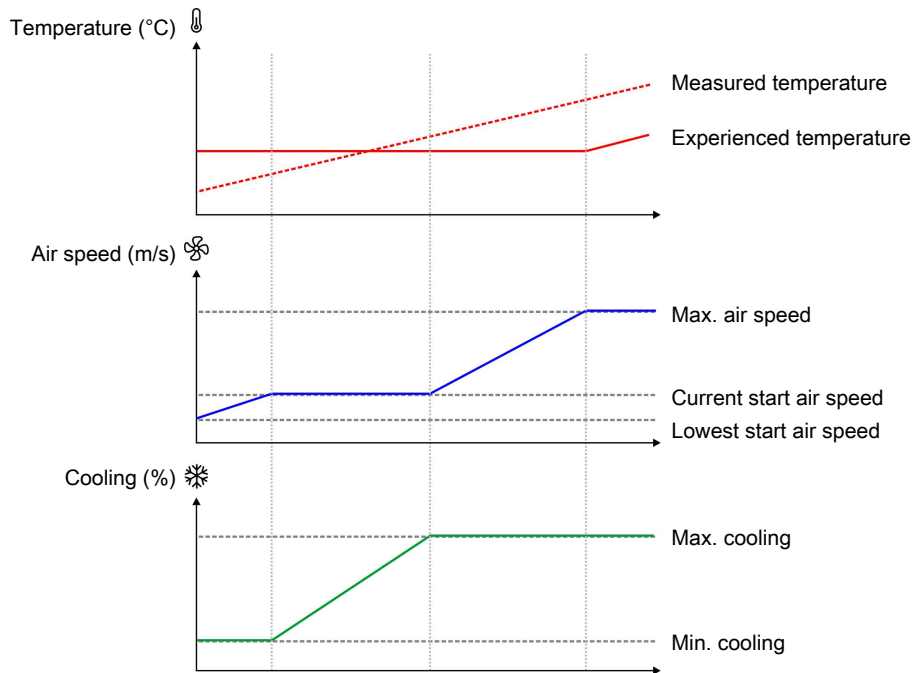

Figure 37: The cooling starts already at low air speed to maintain the required inside temperature. When the cooling cannot maintain the temperature, the air speed is increased again.

4.6.5.2.3 Tunnel cooling start based on inside temperature

Operation | Climate equipment card | Tunnel cooling

Start temperature	Setting the number of degrees which the experienced temperature - at maximum tunnel ventilation - must exceed the Temperature setpoint , before the tunnel cooling starts.
Humidity to stop tunnel cooling	Setting the percentage of air humidity that makes the controller stop the tunnel cooling.

4.6.5.3 Pad rinsing

Operation | Climate equipment card | Tunnel cooling | Tunnel cooling

Runtime since last bleed off (Pad rinsing)	Reading of the time tunnel cooling has been running since the last bleed off.
Total runtime	Reading of total bleed off running time. Can be used as an indicator of whether cooling pads need to be replaced.

 Menu button |  **Strategy** |  **Tunnel cooling**

Bleed off active	Connection and disconnection of the pad rinsing function.
Time for bleed off (Pad rinsing)	Setting how long time tunnel cooling must have been running until the pad rinsing starts. Bleed off does not start while tunnel ventilation is active.

4.7 Heating

4.7.1 House heaters

Room heaters are used to heat the entire house and cold areas in the house. All heaters connected as room heaters are regulated according to the same temperature setpoint.

Room heating can be regulated as common or individual heating.

Common house heaters: Up to two heaters are regulated according to a common heating requirement.

Individual house heaters: For each heater, choose which sensors are to control the heating requirement.

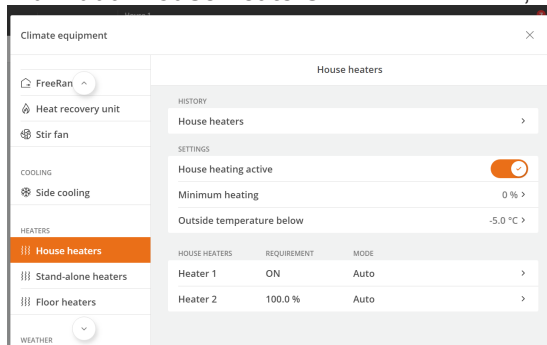

Operation | Climate equipment card | House heaters

House heating active Connection and disconnection of house heaters.

When you want to stop the heat supply in the house, disconnect heating. The controller will then automatically turn off the heat supply.

Inappropriate regulation

- If you turn off the heat supply manually without disconnecting heating on the controller, the regulation of the ventilation will be inappropriate as the controller will try to regulate based the assumption that heating is still available.

Heat offset

In houses with heating systems, the controller regulates the inside temperature according to the set temperature, **Temperature**, and according to a lower temperature limit, **Absolute heat setpoint**.

Menu button | Strategy | Climate | Temperature | Inside temperature

Heat offset Set the number of degrees the inside temperature must drop below the required temperature before the controller activates heat supply.

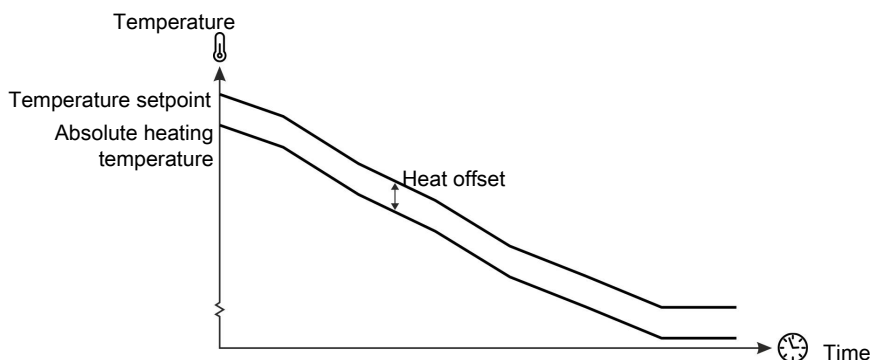

Figure 38: Set heat offset

If you want to increase the **Temperature setpoint** without increasing the **Absolute heat setpoint**, you must first adjust the **Temperature setpoint**, and then increase the **Heat offset**, by the corresponding number of degrees.

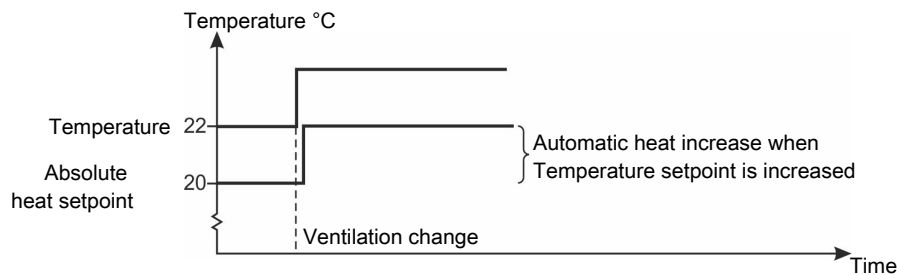
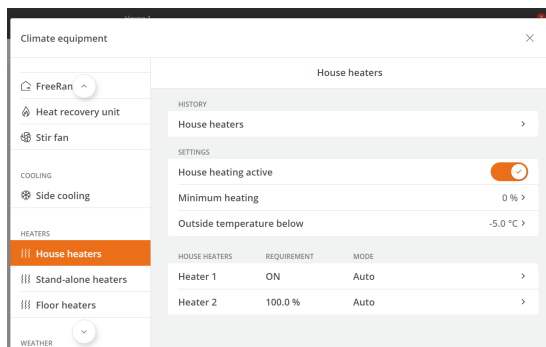

Figure 39: Heat supply

Note that when you increase the **Temperature setpoint**, the **Absolute heating temperature** will increase correspondingly so that the offset between the two values will always be the same.

4.7.1.1 Minimum heating



Minimum heating is a function which the controller activates in cold weather. Minimum heating can e.g. Minimize ice formation in the air inlet. When the outside temperature is set to **Outside temperature below**, the controller constantly adds the minimum heat.

Operation | Climate equipment card | House heaters.

Minimum heating

Setting of the percentage of the heating system capacity at which the system opens at minimum heating.

Outside temperature below

Setting of the outside temperature that activates the **Minimum heating** function.

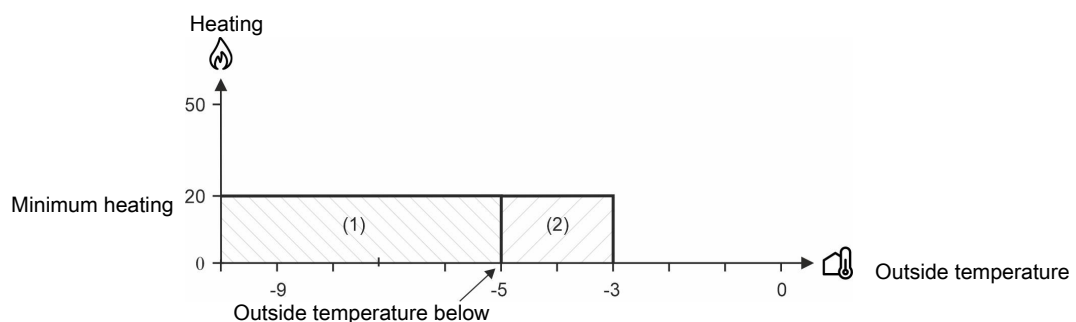

Figure 40: Minimum heat at decreasing or increasing outside temperature

(1) At decreasing outside temperature: The controller switches on the heat when the outside temperature is lower than **Outside temperature below** (-5°C).

(2) At increasing outside temperature: The controller only switches off the heat when the outside temperature is 2 °C above **Outside temperature below**. This prevents the heating system from connecting and disconnecting continuously when the outside temperature fluctuates around the set **Outside temperature below**.

4.7.2 Stand-alone heating

Stand-alone heaters are used, e.g., in cold areas of the house to equalize temperature differences.

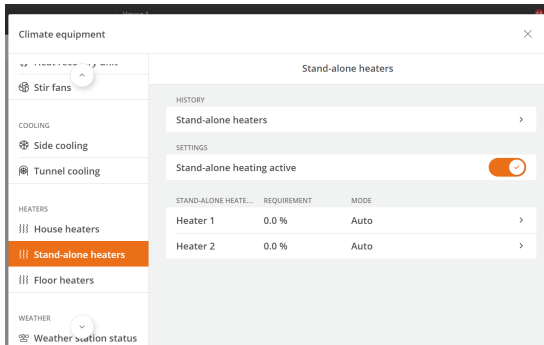

You can use up to 4 stand-alone heaters to which a local zone should be assigned at controller setup.

The controllers regulate the stand-alone heaters independently of the room heating.





As heating is concentrated in the local zones, the temperature outside the local zones can be kept down to reduce heat consumption.

 **Operation | Climate equipment card |  Stand-alone heaters.**

Stand-alone heater 1 active Connecting or disconnecting all stand-alone heaters.

 **Operation | Climate equipment card |  Stand-alone heaters** and the desired stand-alone heater in the table.

Stand-alone heating active Connecting or disconnecting the individual stand-alone heater.

 **Operation | Temperature card |  Stand-alone heaters.**

Stand-alone heater set-point Setting of the temperature which is the lowest temperature allowed in the local zone. When the temperature is lower than this setting, the heater supplies heat.

The page **Operation | Climate equipment card | Stand-alone heaters** provides furthermore access to:

- Graphic history curve.
- Current requirement
- Manual mode

4.7.3 Floor heating

For example, floor heating is used to limit the heat loss of the animals through the floor and to dry out the livestock house.

The controller can control the floor heating with or without a temperature sensor. Using a connected sensor, the controller will keep the floor heating at a set floor heating temperature. Without the sensor, the controller will supply heat based on a set percentage of the capacity of the floor heating system.

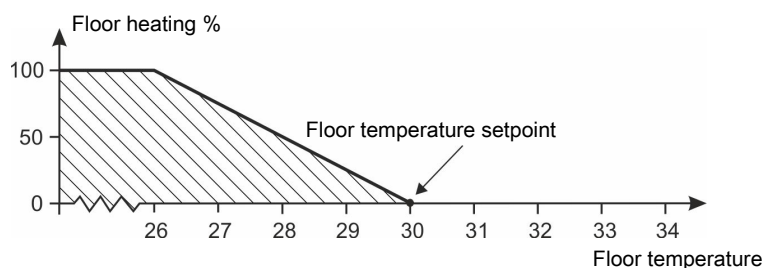

Figure 41: Floor heating with temperature sensor

The floor heating system runs at 0-100% to keep the floor heating temperature at the set floor temperature.

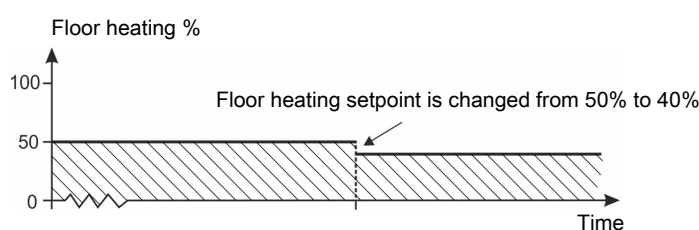

Figure 42: Floor heating without temperature sensor

The floor heating works with a set percentage of the capacity of the heating system. Without the sensor, it is not possible to determine which temperature the floor should have.

☰ Menu button | 📄 Strategy | 📌 Temperature | 🏠 Floor heating

Floor heating	Determination of strategy via batch curve for floor heating.
Outside temperature control	Connection and disconnection of outside temperature control. The function is intended for areas with a high daytime temperature, where it renders possible to turn off the floor heat during the day.
Stop heating at outside temperature above	Setting the outside temperature that causes the climate controller to deactivate floor heating.

🏠 Operation | 📄 Temperature card | 🌡️ Floor heating.

Setpoint	Setting of floor temperature (only with sensor). Setting of the percentage that the floor heating system shall operate with (only without sensor).
Minimum floor heating	Minimum floor heating is used in temperature-controlled floor heating. The function causes the floor heating system to run at least at the set percentage of the capacity of the heating system. Even if the current floor temperature is higher than the Floor temperature setpoint , the heating system will continue to provide floor heating. Minimum floor heating can be used to maintain a specific floor heating temperature in the livestock house and thus influence the distribution of the animals.
Activate minimum heating at an outside temperature below	Setting an outside temperature that causes the controller activate minimum floor heating.

Outside temperature control	Connection and disconnection of outside temperature control. The function is intended for areas with a high daytime temperature, where it renders possible to turn off the floor heat during the day.
Stop heating at outside temperature above	Setting the outside temperature that causes the climate controller to deactivate floor heating.

4.8 House status Active house - Empty house

The controller has 2 different modes of operation, one for when there are animals in the house and one for when the house is empty.

With animals in the house – active house. Control takes place according to the automatic settings and strategies and all alarms are active.

Without animals in the house – empty house. Control takes place according to the in-between batches setting **Empty**. Only active alarms are alarms for CAN communication and temperature surveillance for **Empty**.

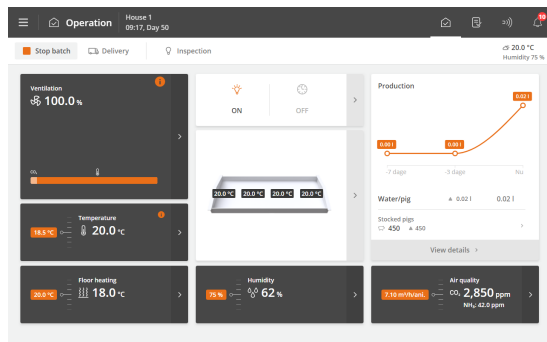

Press  **Operation**.

Press  **Stop batch** to change house status to **Empty**.

or

Press  **Start batch** to change to house status active.

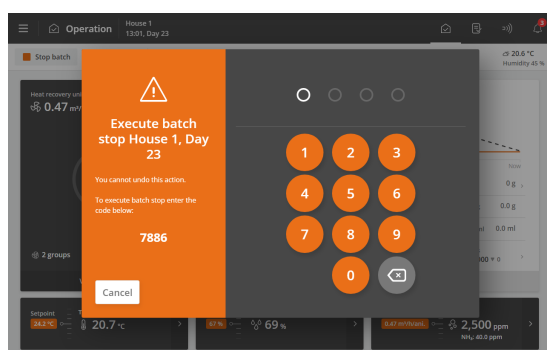

The change between active and empty house is done manually by the user. It is critical for the animals that the change does not happen by mistake. The function is therefore protected with a code entry.

Enter the displayed code to change the house status.

The change takes place immediately when the fourth digit is entered.

Active house

It may be an advantage to change the status to active house 1-3 days before stocking the animals. This way the controller has time to adapt the climate to the needs of the animals and to feed in the house.

When the house status changes to active, the day number changes to **Start at day**, and the controller controls according to the automatic settings.

(Be aware that it can cause problems with the history of production data if you change the **Day number** after the house status is set to active. This setting should only be used for service).

Empty house

The house status should not be changed to **Empty** until the house has been depopulated.

Then the controller disconnects the adjustment and controls according to the settings for **Empty**. It protects the animals in case a house is set to **Empty** by mistake.

If the house is to be completely closed, the settings of the function **Empty** must be reset. See the section Empty house [▶ 88].

When the house status changes to **Empty**, the controller resets all settings that deviate from the strategy and settings made during the previous batch.

4.8.1 Empty house safety



This section is relevant only to houses with 2-house controllers.

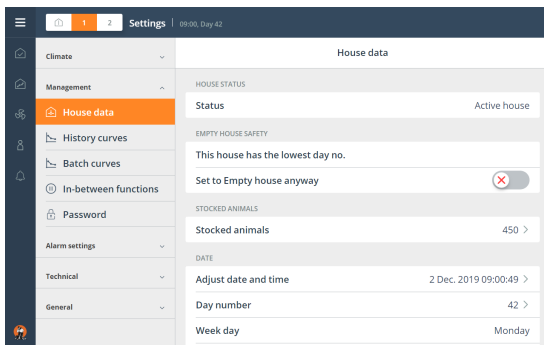

The house with the lowest day number cannot immediately be set to **Empty house**.

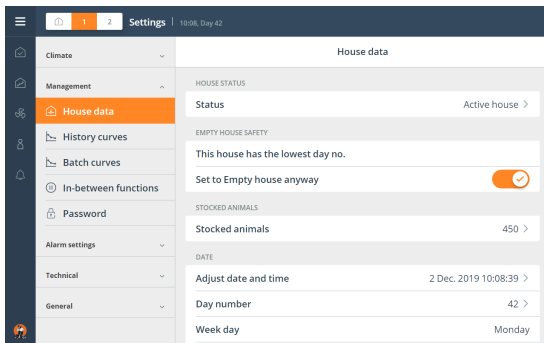

Not until you have selected **Yes** for **Set to Empty house anyway**, can you change the status to **Empty house**.

This menu is only shown for the house with the lowest day number.

4.9 Between batches

4.9.1 Soaking

Soaking will soak the house with water, loosening dust and dirt. It will not only reduce the amount of dust during the subsequent cleaning process, which also becomes easier.

In soaking mode, the ventilation must stop to maintain the humidity in the house. The soaking system adds humidity for a number of minutes (**ON time**) for each interval (**Cycle time**) in the total time, during which the soaking should last.

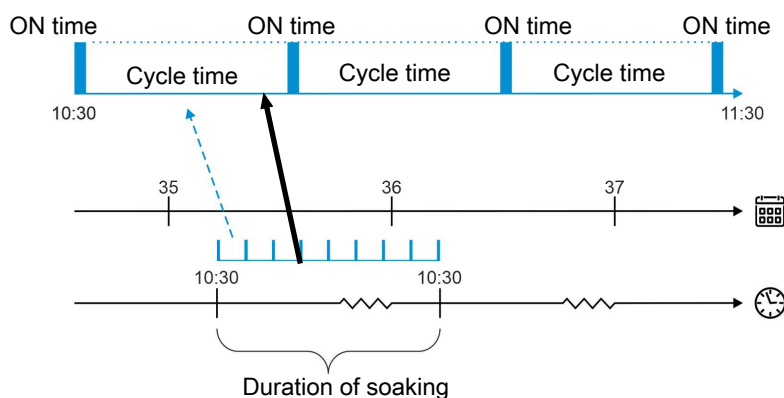

Menu button | Between batches | Soaking

Duration of Soaking	Setting the number of hours during which the function is active and supplies humidity in intervals.
Cycle time	Setting the intervals in which the soaking system is active.
ON time	Setting the active period for soaking.
Ventilation	Setting the percentage of nominal ventilation. When the house is in Empty mode, the function is used to open a number of ON/OFF air outlets.

Air inlet

Roof inlet flap	Setting of flap position for the roof inlets (roof).
Roof inlet fan	Setting of speed control for the roof inlets (roof).
Recirculation inlet	Setting of recirculation fan for the roof inlets (roof).
Side inlet	Setting the flap opening for side air inlet (side).
Tunnel inlet	Setting of the tunnel opening (tunnel).
HRU inlet flap	Setting of flap opening for air inlet for heat recovery unit.
HRU HRU inlet fan	Setting of fan speed controller for heat recovery unit.

Air outlet

Air outlet 1 flap	Setting the flap opening for air outlet. When the house is in Empty mode, the function is typically used to open the step-less flap.
Air outlet fan speed	Setting of speed control for air outlet. When the house is in Empty mode, the function is typically used to turn off the step-less fan.

4.9.2 Washing

During washing the house manually, ventilation must run again to start changing the air in the house.

 Menu button |  **Between batches** | **Functions** |  **Washing**

Duration of Washing	Setting the number of hours during which the function is active.
Ventilation	Setting the percentage of nominal ventilation.

Air inlet	
Roof inlet flap	Setting of flap position for the roof inlets (roof).
Roof inlet fan	Setting of speed control for the roof inlets (roof).
Recirculation inlet	Setting of recirculation fan for the roof inlets (roof).
Side inlet	Setting the flap opening for side air inlet (side).
Tunnel inlet	Setting of the tunnel opening (tunnel).
HRU inlet flap	Setting of flap opening for air inlet for heat recovery unit.
HRU inlet fan	Setting of fan speed controller for heat recovery unit.

Air outlet	
Air outlet 1 flap	Setting the flap opening for air outlet. When the house is in Empty , this function is typically used to open the stepless flap.
Air outlet fan speed	Setting of speed control for air outlet. When the house is in Empty , this function is typically used to turn off the stepless fan.
HRU outlet flap	Setting of flap opening for air inlet for heat recovery unit.
HRU outlet fan	Setting of fan speed controller for heat recovery unit.

4.9.3 Disinfection

Disinfection is carried out manually by adding disinfectant to the water.

A certain temperature must be maintained in the house during disinfection in order for the disinfectant to have optimal effect (often over 20 °C).

The house shuts off the ventilation system and supplies heat as needed to maintain the correct temperature for disinfection.

Heating can be supplied as room heating or floor heating. A desired temperature is set when room heating is used.

 Menu button |  **Between batches** | **Funktions** |  **Disinfection**

Duration of Disinfection	Setting the number of hours during which the function is active.
Temperature	Setting of the temperature it needs to be in the house during disinfection.
Floor heating setpoint	Setting of floor heating addition. When floor heating is used, the percentage the floor heating system will operate at must be set. The floor heating stops when the inside temperature exceeds the temperature that has been set.

Air inlet	
Roof inlet flap	Setting of flap position for the roof inlets (roof).
Roof inlet fan	Setting of speed control for the roof inlets (roof).

Recirculation inlet	Setting of recirculation fan for the roof inlets (roof).
Side inlet	Setting the flap opening for side air inlet (side).
Tunnel inlet	Setting of the tunnel opening (tunnel).
HRU inlet flap	Setting of flap opening for air inlet for heat recovery unit.
HRU inlet fan	Setting of fan speed controller for heat recovery unit.

Air outlet

Air outlet 1 flap	Setting the flap opening for air outlet. When the house is in Empty , this function is typically used to open the stepless flap.
Air outlet fan speed	Setting of speed control for air outlet. When the house is in Empty , this function is typically used to turn off the stepless fan.
HRU outlet flap	Setting of flap opening for air inlet for heat recovery unit.
HRU outlet fan	Setting of fan speed controller for heat recovery unit.

4.9.4 Drying

 Menu button |  **Between batches** | **Functions** |  **Drying**

Duration of Drying	Setting the number of hours during which the function is active.
Ventilation	Setting the percentage of nominal ventilation. When the house is in Empty , this function is used to open a number of ON/OFF air outlets.

Air inlet

Roof inlet flap	Setting of flap position for the roof inlets (roof).
Roof inlet fan	Setting of speed control for the roof inlets (roof).
Recirculation inlet	Setting of recirculation fan for the roof inlets (roof).
Side inlet	Setting the flap opening for side air inlet (side).
Tunnel inlet	Setting of the tunnel opening (tunnel).
HRU inlet flap	Setting of flap opening for air inlet for heat recovery unit.
HRU inlet fan	Setting of fan speed controller for heat recovery unit.

Air outlet

Air outlet 1 flap	Setting the flap opening for air outlet. When the house is in Empty , this function is typically used to open the stepless flap.
Air outlet fan speed	Setting of speed control for air outlet. When the house is in Empty , this function is typically used to turn off the stepless fan.
HRU outlet flap	Setting of flap opening for air inlet for heat recovery unit.
HRU outlet fan	Setting of fan speed controller for heat recovery unit.

Heating

Heating	Setting of heat supply.
Floor heating setpoint	Setting of floor heat supply.

4.9.5 Empty house

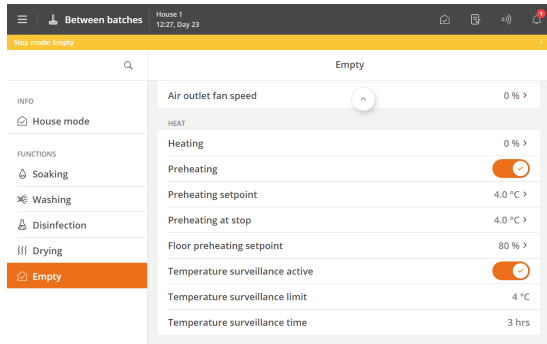

Empty house

The function **Empty** will maintain the air change in the house by allowing ventilation to run at a fixed percentage (50 %) of system capacity. This is to protect the animals in case a house is set to **Empty** by mistake.



When batch status is **Empty**, the controller disables all automatic regulations and operates according to the settings for **Empty**.

All alarm functions - with the exception of temperature monitoring when the house is empty - are switched off. See also the section Temperature surveillance [▶ 89].

4.9.5.1 Preheating

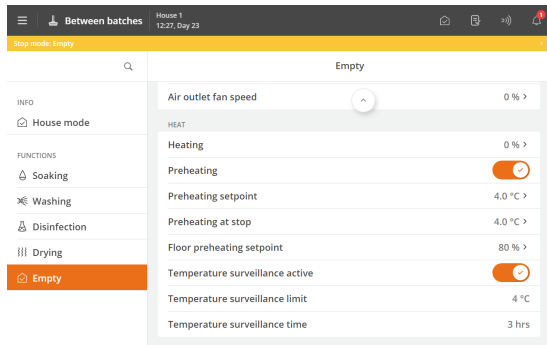

Preheating ensures that the inside temperature does not fall below the set temperature when batch status is **Tom** for a longer period of time.

Thus, the function can also be used to protect the house against frost.

Heating can be supplied as room heating or floor heating.

At batch production the **Preheating at stop** function maintains an inside temperature of 4°C, for example, between two batches. Note that ventilation must be shut off and the heating system must be connected.

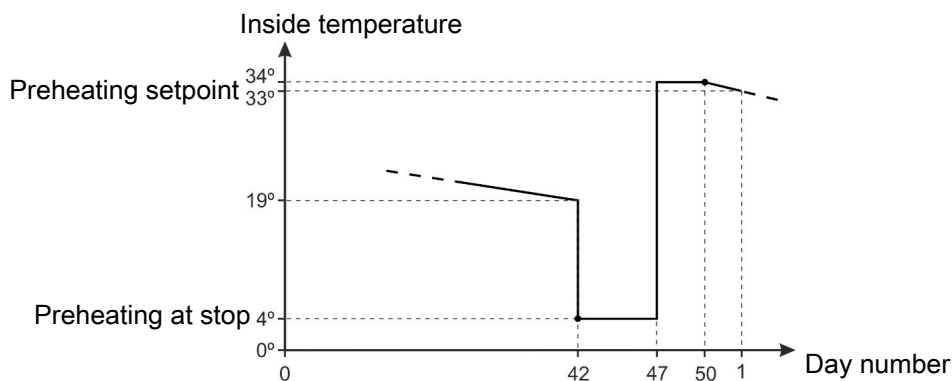

Figure 43: Example of setting of preheating.

Menu button | **Between batches** | **Functions** | **Empty**

Preheating Connection and disconnection of the function.

Preheating setpoint Setting of desired inside temperature at batch start.

Preheating at stop Setting of desired minimum inside temperature between 2 batches.

Floor preheating set-point

Setting of the percent that the floor heating system shall operate with. The floor heating stops when the inside temperature exceeds the temperature that has been set.

4.9.5.2 Temperature surveillance

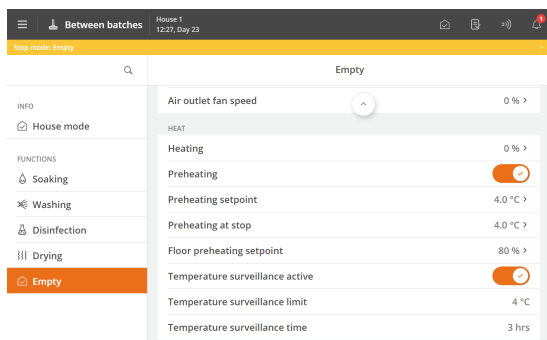

The controller can be secured against incorrect setting to the house status **Empty**.

The controller monitors the temperature in the house for 3 hours after changing the batch status to **Empty**. If the temperature increases in this period by more than 4 °C (indicate there are animals in the house), the controller triggers an alarm and activates the ventilation.

This temperature surveillance is interrupted if an in-between function is activated.

 Menu button |  **Between batches** |  **Functions** |  **Empty**

Temperature surveillance active

Connection and disconnection of the function.

Temperature surveillance limit

Display of the number of degrees the temperature must rise after batch stop.

Temperature surveillance time

Display of the time period when the temperature is monitored after batch stop.

5 Production

The light, water, and 24-hour clock functions are part of the standard software for pigs.

The feature software for pigs also has:

- Advanced dry feeding program with subcircuit and volume dispenser control.
- Production alarm relay.
- Recording key figures, such as water/animal and live and dead animals.

5.1 Animals

Information about the number of stocked animals helps to form the basis for the controller's calculations relating to climate control.

With feature software for production, these options are expanded with more options for registration of key figures for live and dead animals and calculating mortality.

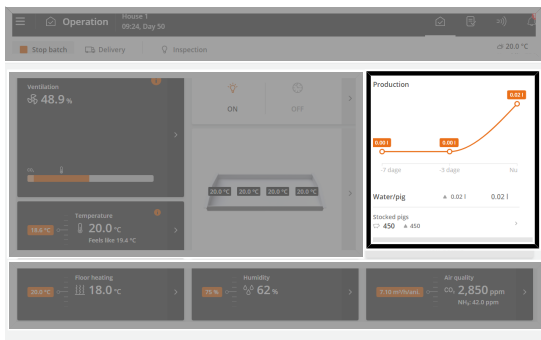

Operation. The most important values and settings for animals in the livestock house can be viewed and entered via the **Production results** card.

A graphic on the face of the card illustrates the current water values during the last 7 hours. Furthermore the number of animals in the house is displayed and access to registration of new data is available.

Operation | Production results card | Animal

Stocked

Entry of the total number of animals at batch start.

If animals are stocked or removed from the livestock house in the course of a batch, it must be recorded in the menu **Add/remove animals** or **Number of dead animals**.

5.2 Pig weighing

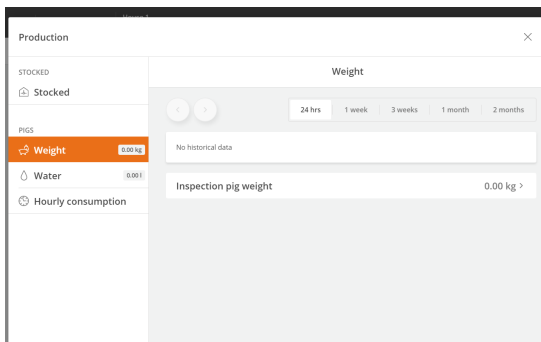

Operation | Productions results card | Scale

Manually weigh a number of animals.

Enter the average weight of the animals in the production controller as **Inspection weight**.

The manual weighings should be carried out on the same day and time of the week to ensure that the weighings are comparable.

5.3 Water

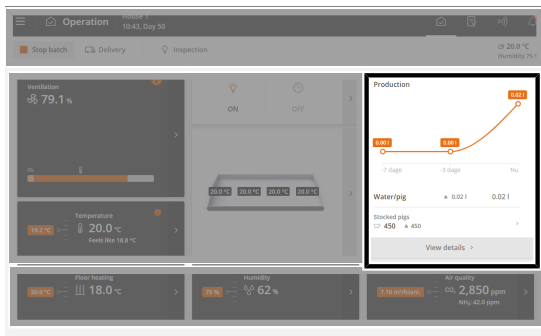

Operation | Production results card | Water

Water data is collected and presented in graphs and outlines, including important key figures.

Water last week			
	Day no.	Amount	Consumption
	Today	20 l	100.0 %
	Yesterday	0 l	0.0 %
	Two days ago	0 l	0.0 %
	Three days ago	0 l	0.0 %
	Four days ago	0 l	0.0 %
	Five days ago	0 l	0.0 %
	Six days ago	0 l	0.0 %
	Seven days ago	0 l	0.0 %

Water consumption

The controller records the water consumption in liters to provide a complete overview. The water consumption is also recorded in percent to make sudden changes visible.

Under normal conditions, the percentages will increase by a few percent per day as the age of the animals increases.

5.4 Light

5.4.1 Light program

In principle, the light control works as feed control.

The light program can contain up to 16 programs starting on different days numbers. A program is maintained from one day number to the next day number. If no programs have a higher day number, the program applies to the rest of the batch.

Set for each day number (up to 16):

- Number of periods per day
- Start and stop time

Please note that:

- The light up to the first day number is on 24 hours a day with the same light intensity as for Day 1.
- That there is no access to light outside the periods selected.
- Light is available around the clock if a start time is set from 00:00 to 24:00.

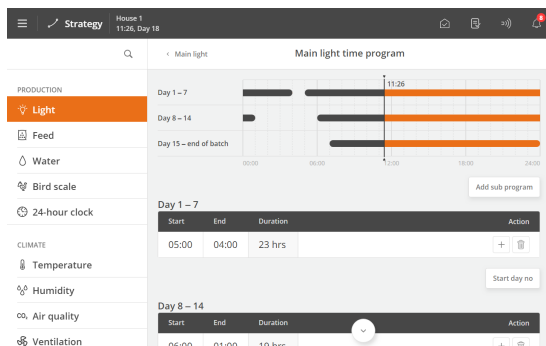

Menu button | Strategy | Light

Press the field in the column **Start** to change the start time.

Press the field in the column **End** to change the stop time.

Press **+** to add a new period and set the start and stop time.

Press the field **Start day no.** to change the day number of the period, if required.

Press **Add subprogram** to add a new day number.

The blocks on the timeline show when and how long the light is on.

Press **🗑️** to delete a period.

5.4.2 Main light

The light intensity of the main light is the same throughout the day, but the controller has the reduced light, and dawn and dusk options.

Operation | Program overview card | Main light settings

Main light intensity set-point	The setting of light intensity for the main light (with light dimmer).
Main light off intensity setpoint	The setting of minimum light intensity (with light dimmer). The setting of light intensity when the lighting program is OFF.
Main light sensor value	Reading of the current light intensity measured by the light sensor (with light sensor). When there are more sensors, the controller shows an average value.
Light sensor history	Graphic display of the history curve values in different time intervals from 24 hours to 2 months.

Menu button | Strategy | Light

Main light time program The controller automatically regulates the light in the house based on the values you indicate in the **Light time program** menu.

The time program is set as described in the section Light program [► 92].

Main light intensity curve The setting the light intensity of each day number.

Dusk and dawn

Settings of periods with increasing and decreasing light intensity for transition between light and darkness in the house.

See also the section Dawn and dusk [▶ 93]. Only available in houses with light dimmers.

5.4.3 Dawn and dusk

The function is intended for houses with standard lighting control.

When a light dimmer is used, the light level can be controlled so that a light period starts with "Dawn" where the light is changed from "Night" to "Day". Similarly, a light period ends with "Dusk".

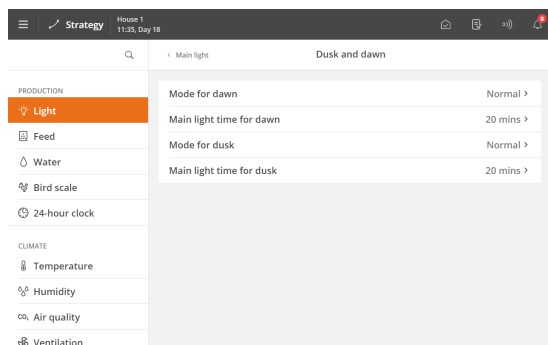

Over a set period, the controller changes the light to the required level.

Periods for dawn and dusk can be set independently.

Set the duration of the individual periods and the value of the light intensity when the period expires.

Start time: 14:00

Dawn: 00:20

Dusk: 00:30

Stop time: 16:00

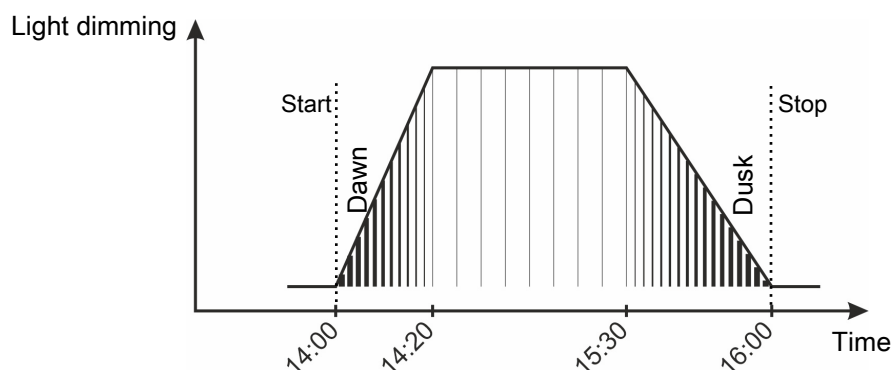

Figure 44: Normal light dimming Dawn and dusk are integrated in the light period.

Menu button | Strategy | Light

Light color

Menu for setting the time and light color (in Kelvin).

The controller automatically adjusts the light color in the livestock house based on the values you set in the menu **Light color program**.

5.4.4 Inspection light

The inspection light is used to control the light when entering the house. The light is controlled through a menu button or an external push button.

All types of light can be used as an inspection light (main light, slave light, and extra light).

Operation | Inspection

Duration

Setting for how long the inspection light should be on.

The light automatically returns to normal light after the set period.

active

Activation of the inspection light.

When the inspection light is on, it is displayed with a colored icon.

light intensity

Setting the light intensity of the inspection light.

5.5 24-hour clock

The 24-hour clock function allows you to automatically turn on and off equipment at specific times or time intervals. In addition, the 24-hour clock allows you to choose how often equipment will run in a week. It is done by applying a week program.

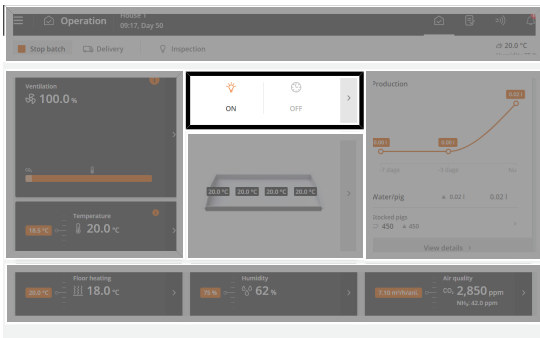

Operation. When 24-hour clock is on, it is displayed with a colored icon on the card **Program overview**.

The card provides access to view and change the programs of all the 24-hour clocks.

In each program you must set the following:

- Start time
- Duration

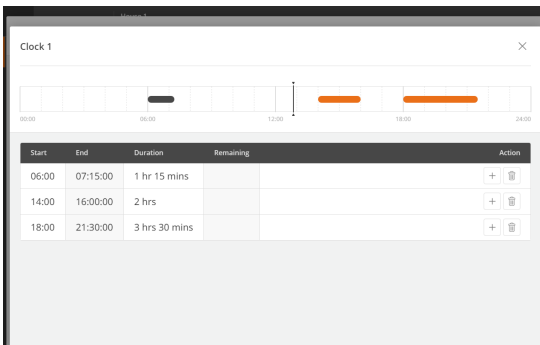

Operation | Program overview-card | Clock

Press the field in the column **Start** to set a start time.

Press the field in the column **Duration** to set the duration of the period.

Press **+** to add a new period, then set the start time and duration of the period.

The blocks on the timeline show when and how long the 24-hour clock is on.

Outside the selected periods, the 24-hour clock is off.

Press to delete a period.

24-hour clock with week program

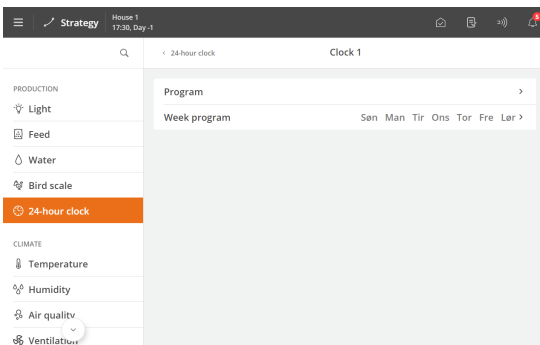

Menu button | **Strategy | Production |** **24-hour clock**

Select which days the 24-hour clock is on.



Figure 45: If an ON-time runs past midnight on a day when the 24-hour clock is not active, the function will remain ON until the time has elapsed.

6 Alarm settings

The controller has a number of alarms, which it will activate if a technical error occurs or alarm limits are exceeded. A few of the alarms are always connected, e.g. power failure. The other alarms can be activated / deactivated, and for some of them, you can even set the alarm limits.



The user is always responsible for ensuring that all alarm settings are correct.

See also the section Alarms [▶ 25].

6.1 Climate

6.1.1 Temperature alarms

☰ Menu button | ⚙ Settings | 🔔 Alarms | 🌡 Climate | 🌡 Temperature

Actual alarm limit	The temperature alarm has a variable alarm limit. It is, e.g., possible to compensate for changes in the outside temperature. Display of the temperature limit that will trigger the alarm.
Absolute high temperature	The alarm for absolute high temperature is triggered by an actual temperature, such as 32°C. The controller triggers the absolute high temperature alarm when only one inside temperature sensor measures a temperature that exceeds this setpoint. The absolute high temperature is set as a temperature curve.
High temperature limit	The temperature alarm for high temperature is only activated when the batch state is Active house . The alarm is set as an excess temperature to Temperature setpoint .
Low temperature limit	Alarm for excessively low temperature in relation to the Temperature setpoint .

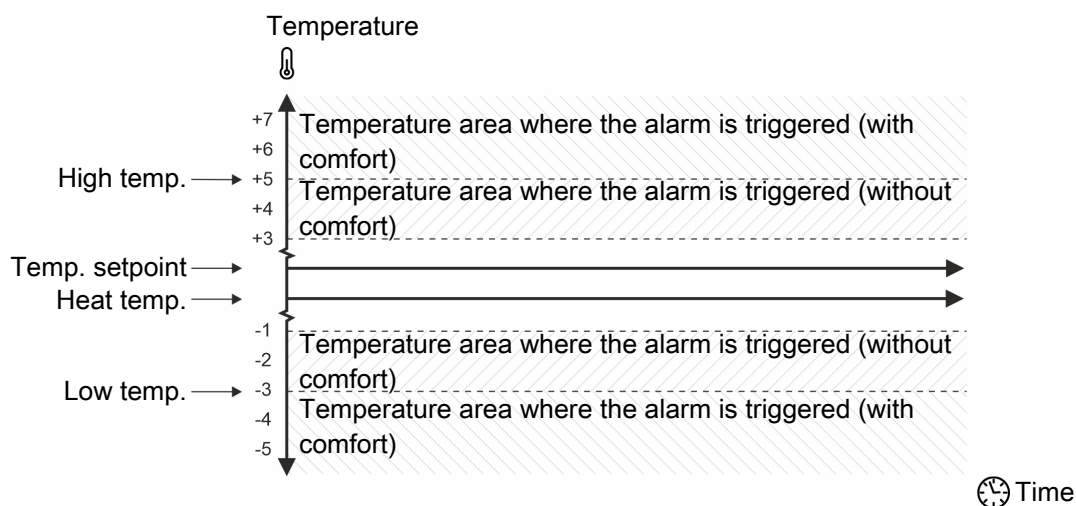

Figure 46: Alarm high and low temperature

If the controller is set with the functions comfort temperature or humidity control with temperature reduction, the controller will add the number of degrees that the comfort temperature is set to, to Temperature or subtract the number of degrees that humidity control with temperature reduction is set to, from Temperature. The high temperature alarm will therefore be calculated in relation to Temperature plus an addition for Comfort temperature or minus Reduction for humidity control.

Summer temp. at 20 °C and 30 °C outside

The function has a varying alarm limit that monitors changes in the high outside temperature. When the temperature rises, the alarm limit will also rise. It will thus postpone the time when the high temperature alarm is triggered.

The controller only triggers the alarm if the inside temperature also exceeds the high temperature alarm.

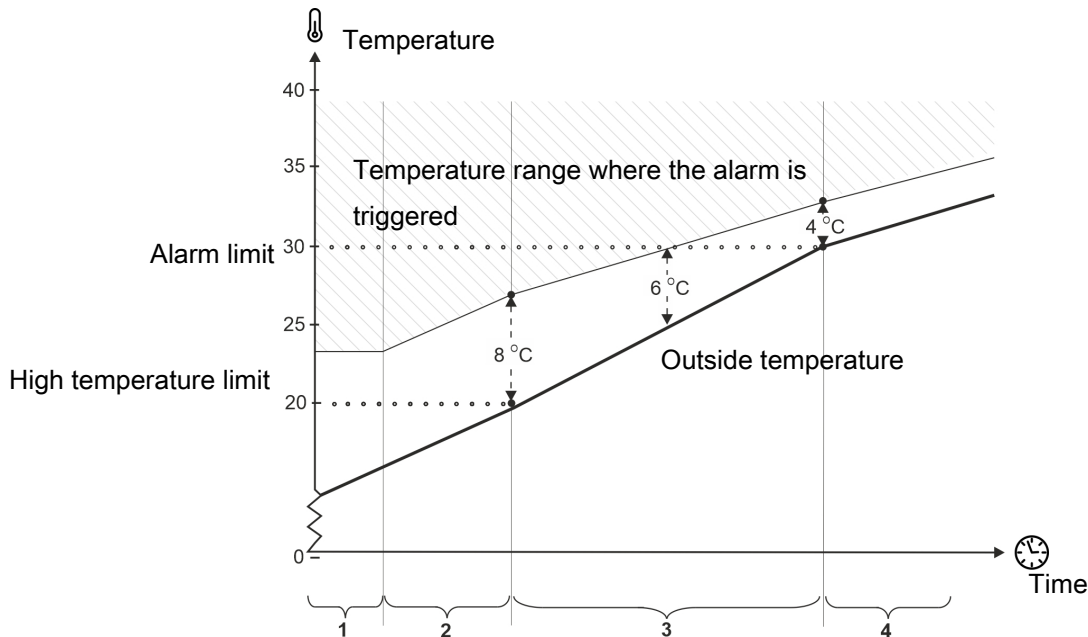

Figure 47: Summer temperature at 20°C and 30°C outside

1. The alarm limit does not fall below the High temperature limit.
2. Below 20°C outside, the alarm limit is 8°C, staggered in relation to the outside temperature.
3. Between 20°C and 30°C, there is a gradual transition from 8°C to 4°C. At an outside temperature of, e.g., 25°C, the inside temperature must be 6°C higher (above 30°C) for the alarm to be triggered..
4. Above 30°C outside, the alarm limit is 4°C, staggered in relation to the outside temperature.

Temperature difference in tunnel Front/Rear

The alarm is active at tunnel ventilation where ventilation is regulated according to an average value of the Front and Rear temperatures.

Two zones

The controller generates an alarm when the temperature difference between the Front and the Rear zones exceeds the set number of degrees.

Temperature surveillance

The alarm can be generated at batch stop.

In the event of this alarm, the controller will start all of the ventilation again.

To deactivate the alarm, the controller must be set back to **Active house**.

6.1.2 Humidity alarm

☰ Menu button | ⚙ Settings | 🔔 Alarms | 🌡 Climate | 💧 Humidity

Absolute high humidity limit

The controller triggers the alarm for absolute high humidity when the humidity exceeds the setpoint. This may be due for example to lack of ventilation or a technical sensor error.

6.1.3 Inlet and outlet alarm

☰ Menu button | ⚙ Settings | 🔔 Alarms | 🌡 Climate | 🚪 Inlet and outlet alarm

Inlet and outlet alarm	The inlet and outlet alarms are technical alarms. The controller triggers an alarm if the actual flap position on the air inlet or air outlet deviates from the setpoint that the controller has calculated as correct.
Alarm type	
Missing fan setting	This alarm indicates that the fan voltage has not been set in the Installation menu. When a 0-10 V output fan has been selected, a voltage value must be set which corresponds to the fan running at low and full speed.
Tunnel cooling temperature	Alarm for when the inside temperature exceeds the outside temperature. This indicates an error in tunnel opening.
Missing fan setting	This alarm indicates that the fan voltage has not been set in the Installation menu. When a 0-10 V output fan has been selected, a voltage value must be set which corresponds to the fan running at low and full speed.

6.1.4 Sensor alarm

 Menu button |  Settings |  Alarms | Climate

Error inside temperature sensor	<p>The controller triggers an alarm if the sensor is short-circuited or disconnected.</p> <p>Without this sensor, the controller cannot control the inside temperature, and apart from the alarm, the error will also trigger an emergency control of the ventilation system, which will open 50 %.</p> <p>The alarm is always a hard alarm.</p>
Error outside temperature sensor	The controller triggers an alarm if the outside temperature sensor is short-circuited or disconnected.
Error outside temperature sensor low (-35°C)	<p>Selection of whether the controller should monitor whether there is an error in the outside temperature sensor.</p> <p>The function is intended for use in areas where the outside temperature usually does not fall below -30 °C.</p>
Misplaced outside sensor	The alarm indicates whether the sensor is exposed to solar heating and therefore displays an incorrect outside temperature. The controller triggers an alarm when the inside temperature measured by the controller is the number of degrees below the outside temperature that the function is set to (e.g. 5 °C).
Error humidity sensor Outside humidity sensor failure	The controller triggers an alarm when the humidity sensor is disconnected or the air humidity is lower than humidity setpoint.
Error floor heating temperature sensor	<p>The controller triggers an alarm if the sensor is short-circuited or disconnected.</p> <p>The alarm is always a hard alarm.</p>

6.1.5 Tunnel cooling sensor alarm

 Menu button |  Settings | **General** |  Alarms | Climate

Alarm for tunnel opening failure	<p>The controller triggers an alarm when the tunnel cooling temperature exceeds the outside temperature by the number of degrees you set for Tunnel cooling sensor alarm limit. Tunnel opening failure</p> <p>The alarm is only active at tunnel ventilation.</p>
Cooling pump failure	The controller triggers an alarm when the tunnel cooling temperature exceeds the outside temperature by the number of degrees you set for Tunnel cooling sensor alarm limit. Cooling pump limit

Tunnel cooling sensor 1 alarm	The controller triggers an alarm if the sensor is short-circuited or disconnected. In case of sensor failure, the controller will adjust tunnel cooling according to the outside temperature + 2 °C.
--------------------------------------	---

6.1.6 Pressure sensor

 Menu button |  Settings | General |  Alarms | Climate

Pressure sensor	With the function Sensor alarm delay you can postpone the alarm signal so that the alarm is not triggered by transient changes of the pressure level in the house, e.g. when a door is opened. The controller triggers an alarm when the pressure in the house drops below or exceeds the settings of Pressure high limit/Pressure low limit .
------------------------	--

6.1.7 CO2 alarm

 Menu button |  Settings |  Alarms | Climate

CO2 alarm	The controller triggers an alarm if the values for the sensor fall below or exceed the setpoints.
------------------	---

6.1.8 NH3 alarm

 Menu button |  Settings |  Alarms | Climate

NH3 alarm	The controller triggers an alarm when the NH ₃ content of air in the house is registered to be above or below the alarm limit. From the factory the low alarm is disconnected. The alarm limit is factory pre-set at such a low level (5%) that the alarm is normally only triggered by actual sensor errors. In the case of a high alarm (30 ppm) the controller ventilates 100%.
------------------	---

6.1.9 Weather station alarm

 Menu button |  Settings |  Alarms | Climate

Sensor alarm for wind speed	The controller triggers an alarm when the voltage for wind speed is too low. This indicates a sensor error.
Sensor alarm for wind direction	The controller triggers an alarm when the voltage for wind direction is too low. This indicates a sensor error.

6.1.10 Heat recovery alarm

 Menu button |  Settings |  Alarms | Climate

Heat recovery unit	The flap alarm for the heat recovery unit works in the same way as the other flap alarms, see Inlet and outlet alarm [▶ 96]. The controller can generate an alarm if the temperature sensor in the air inlet is short-circuited or disconnected. The controller generates an alarm when the temperature in the air inlet is below the set limit (-5 °C).
---------------------------	--

6.1.11 Dynamic Air Alarm

 Menu button |  Settings |  Alarms | Climate

Dynamic Air

The Dynamic Air alarm may be due to a mechanical error in the fan, the pressure sensor or the flap position. The controller triggers an alarm if the measurement of the ventilation output deviates from the calculated ventilation requirement.

Check the fan while it is running. Further troubleshooting must be carried out by technically trained personnel.

6.1.12 Emergency control

6.1.12.1 Emergency opening

The controller has emergency opening as a standard function regardless of whether an actual emergency opening is installed. As long as there is power, the controller will open the ventilation system 100 % in case of a relevant alarm - even if it is cold outside.

The emergency opening can be activated by five types of alarms.

Activated by	Side	Tunnel (CT, T)
High temperature	Yes	
Absolute high temperature	Yes	Yes
Absolute high humidity	Yes	Yes
Pressure high alarm	Yes	Yes
Pressure low alarm (negative pressure)	Yes	Yes
Pressure low alarm (positive pressure)	No	No
Power failure	Yes	Yes

It may be an advantage to disconnect absolute high humidity in houses that are placed in areas with very high outside air humidity and in situations when a technical sensor error emerges.

6.1.12.2 Temperature-controlled emergency opening

Temperature controlled emergency opening is only triggered when the inside temperature exceeds the temperature setpoint for emergency opening (**Emergency opening setpoint**). You can read off the setpoint as an actual temperature figure on the controller's display. The emergency opening is also triggered in the event of power failure.

Emergency opening temperature

You can set the temperature at which emergency opening shall occur directly on the emergency opening's adjustment knob. The setting can be read off in the display together with **Temperature setpoint**.

Warning at emergency temp.

The controller can issue a warning that will flash in the display in the event of the **Emergency opening setpoint** being too high in relation to the **Temperature setpoint** (inside temperature). This is especially relevant at batch production and a falling temperature curve. This is where on an ongoing basis you must adjust the **Emergency opening setpoint** downwards. However, too high a setting can also be caused by an error.

The warning function can be connected and disconnected. The setting here should be the number of degrees by which the **Emergency opening setpoint** must exceed the **Temperature setpoint** for the controller issue a warning.

Battery alarm and battery voltage

Temperature controlled emergency opening has a battery that ensures that the emergency opening will open, despite there being a power failure, if the inside temperature exceeds the **Emergency opening setpoint**.

You can read off the current and the lowest measured voltage on the battery. These readings indicate whether you need to replace the battery or whether there may be a technical fault causing the battery alarm.

The controller can trigger an alarm if the battery that operates emergency opening is not working.



Be careful not to set the **Battery voltage limit** too low, as this will actually deactivate the alarm.

6.1.12.3 Emergency inlet

The emergency inlet can be triggered by four types of alarms.

Activated by	
Emergency inlet (temperature)	Set
Absolute high temperature	Connect or disconnect
Error temperature sensor	Connect or disconnect
Power failure	Always trigger

Whether an inside temperature sensor error should trigger the emergency inlet depends on the general climate conditions. If it is very hot, you could profit from using the function. However, if it is cold, you should consider the necessity of using it and whether the animals will suffer.

The emergency inlet has its own temperature setting, **Emergency inlet**, where the number of degrees are entered for the **Temperature setpoint** and any **Comfort temperature**.

This setting enables the air inlet to be opened during a hot season where the air inlet, under normal conditions, is not triggered by the normal high temperature alarm limit.

6.2 Production

6.2.1 Light alarms

☰ Menu button | ⚙ Settings | 🔔 Alarms | Production | Light

Main light alarm	The controller has light alarms for light sensor and main light. When the light alarm is active, light is not regulated according to light sensors, if any.
Light alarm limit	The controller generates the light alarm if the light intensity deviates (+/- 10 lux, Light alarm limit ±) from the required level.
Light alarm delay	It is possible to set a delay for all light alarms to prevent unintended alarms in connection with brief light changes.

6.2.2 Water alarms

These alarms can be disconnected automatically at batch/flock start by setting a **Start alarm day**. In the event of major changes to the number of animals in the house, at least 26 hours should pass before the controller can trigger the alarm.

To avoid triggering false alarms, you can indicate how many days should pass before the controller triggers a water alarm.

☰ Menu button | ⚙ Settings | 🔔 Alarms | Production | Water

Alarms can be automatically disconnected at batch start by setting a **Start alarm day**.

Min. and max. water alarm	<p>The alarms are used for monitoring the animals' drinking patterns.</p> <p>The alarm limits for maximum and minimum water consumption is a set percentage of the normal consumption.</p> <p>The climate controller calculates this normal consumption by comparing the current 24-hour period with the 24-hour period that is two hours older. At 1 P.M., for example, you look at the period from 11 A.M. on the previous day to 11 A.M. on the current day.</p>
	<p>With water control</p> <p>These alarms are used for monitoring leakages and stoppages in the water system.</p>
Not enough water alarm	<p>The alarm is triggered if the water consumption measured by a water meter is too low during a given period of time.</p> <p>It is recommended to set this alarm to 1.0 l/min. and a monitoring time to 30 minutes. An alarm will be generated if consumption is lower than 30 liters each half hour.</p>
Too much water alarm	<p>The alarm is triggered if the water consumption measured by a water meter is too high in a given period.</p> <p>Depending on the capacity of the water supply, the system can supply a certain quantity of water per unit of time.</p> <p>The alarm is triggered when the system has operated at maximum output for too long.</p> <p>If a water relay is installed, the water will be turned off at excessive water consumption.</p> <p><i>Guidelines for alarm limit settings:</i></p> <p>Measure the amount of water flowing per minute to the current water meter. Set the alarm limit for 1 liter less than the measured. Set the monitoring time to 30 minutes.</p>
Start alarm day	<p>In the event of major changes to the number of animals in the house, at least 26 hours should pass before the controller can trigger the alarm.</p> <p>To avoid triggering false alarms, you can indicate how many days should pass before the controller triggers a water alarm.</p>

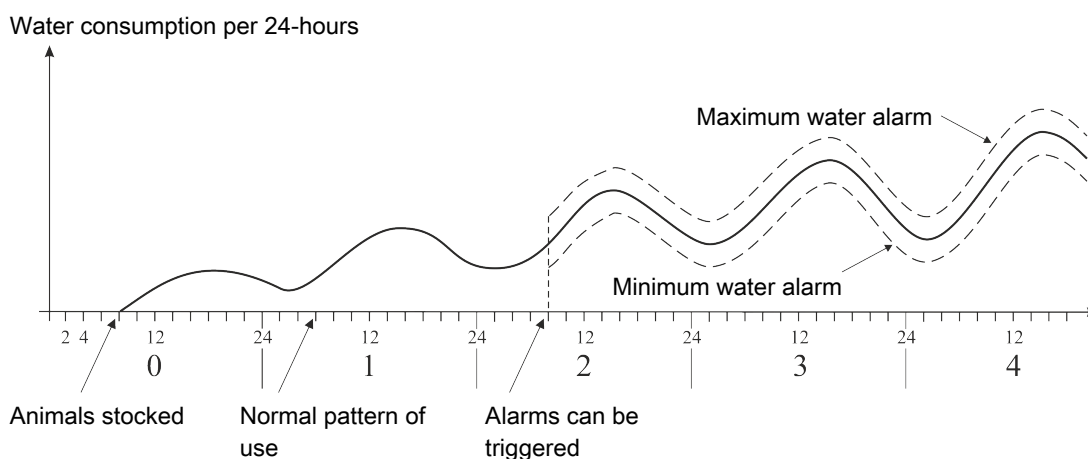

Figure 48: Example of minimum and maximum water alarm

The controller triggers an alarm when the limit for maximum water consumption is exceeded or the consumption is below the limit for minimum water consumption.



There may be various reasons for the fluctuation in the animals' water consumption that will all trigger an alarm. For example, an alarm may be triggered due to stocking more animals or the slaughter of some animals, an outbreak of disease in the livestock or a rupture of the water pipe.

6.3 Auxiliary

6.3.1 Auxiliary sensor alarm

Menu button | Settings | Alarms | Auxiliary

Auxiliary sensors

The controller triggers an alarm if the values for the sensor fall below or exceed the setpoints.

6.3.2 Auxiliary alarms

It is possible to create a number of auxiliary alarms. For example, the controller may give an alarm from a connected motor controller, a water pump or other equipment.

The alarms can be sorted within each column by pressing the heading.

Menu button | Settings | Alarms | Auxiliary | Auxiliary alarm settings

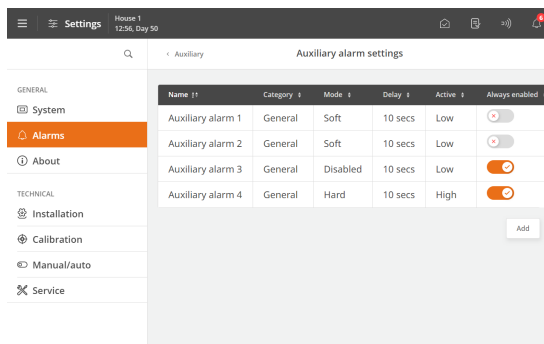

Press **Add** to add a new alarm.

Press **Name** to name the alarm.

Press **Category** to add the alarm to a category.

Select the alarm type **Hard**, **Soft** or **Disabled**.

Set a delay, if required. In this way, the alarm signal can be delayed so that the alarm is not triggered when the alarm limit is briefly exceeded.

Set the activation to take place in the event of high or low input.

Select if the alarm should be active always or from a specific day number.

To delete an auxiliary alarm, press the icon .

After creating the alarm, see the menu  |  | **Installation** | **Show connection** for information about where to connect the extra equipment.

6.4 Master/Client alarms

If the controller is set up to share equipment with other controllers, it gives an alarm if the connection between the controllers is lost. A 'Client' controller will continue to regulate according to the latest received value from the 'Master' controller equipment until the network connection is restored.

Menu button | Settings | Alarms

Connection to Client lost

Select the alarm type **Hard**, **Soft** or **Disabled**.

Connection to Master lost



6.5 Equipment status

When connecting monitoring equipment such as e.g. a current sensor for the individual components of the system (stepless and MultiStep fans), it is possible to get an alarm which can indicate the possible fault type.

There are 3 alarm types:

Low alarm	Possible equipment failure. The equipment may be disconnected by mistake. Alarm due to missing current consumption. For example, MultiStep/stepless may be activated and the power consumption too low, if the emergency stop at the fan is activated.
High alarm	The equipment shows signs of wear. Alarm due to excessive current consumption.
ON alarm	The equipment is active, but should not be in relation to the controller's regulation. Alarming due to current consumption, which should not be there. For example, MultiStep/stepless may be activated and the power consumption too high, if there is an emerging defect in the fan.

Alarms are only triggered when a limit has been exceeded for 5 minutes.

The alarms are set up to match the connected monitoring equipment. This is done in the menu   **Alarms | Equipment status.**

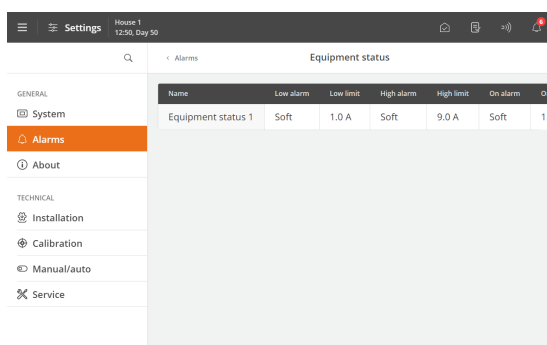

Select the alarm type **Hard**, **Soft** or **Disabled**.

Set voltage ranges for **Low alarm**, **High alarm** and **ON alarm**.

First read the current consumption during normal operation to get an indication of the voltage ranges.

7 Maintenance instructions

The controller requires no maintenance to function correctly.

You should test the alarm system every week.

Use only original spare parts.

Note that the service life of the controller will be extended if it stays connected all the time, as this will keep it dry and free from condensation.

Lock screen for cleaning

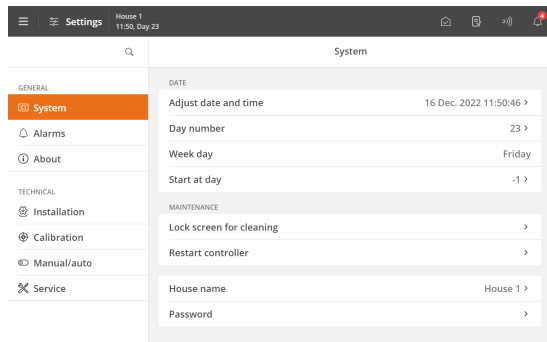

When the controller is to be cleaned, it is possible to lock the screen to avoid inadvertent operation during cleaning.

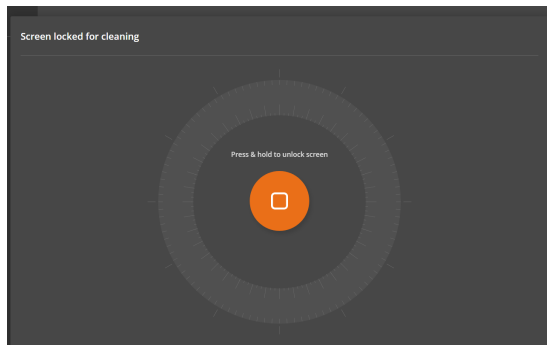

Press  Menu button |  **Settings** | **General** | **Maintenance** | **Lock screen for cleaning** to lock the screen.

Press and hold for 5 seconds to unlock the screen.

The controller automatically cancels the lock after 15 minutes.

7.1 Cleaning

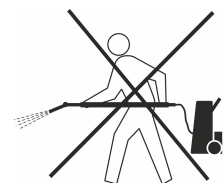

Clean the product with a cloth that has been wrung out almost dry in water and avoid using:

- high-pressure cleaner
- solvents
- corrosive/caustic agents

Big Dutchman International GmbH • Calveslage • Auf der Lage 2 • 49377 Vechta; Germany
Tel. +49(0)4447/801-0 • Fax +49(0)4447/801-237 • big@bigdutchman.com



Big Dutchman.